

ITEM OPPORTUNITY SYNOPSIS

Scouting Number:	2024-019
Name of the item to be scouted:	Steel Caster Capability
State item to be used in:	Illinois
Describe the Item:	
Please describe the item application/the end use of the item.	n/a
Supplier Information:	
Type of Supplier Being Sought (select from the list below):	
Manufacturer	x
Contract Manufacturer	
Distributor	
Other (Please Specify)	
Reason for Scouting Submission (select from the list below)	
2nd Supplier	
Price	
Re-Shore	x
Past supplier no longer available	
New Product Startup	
BABA	
Other (Please Specify)	
Summary of Technical Specifications and Performance Requirements:	
Describe the manufacturing processes (elaborate to provide as much detail as possible)	For ferrous steel casting in machinery manufacturing, the process involves investment casting of Hadfield Manganese steel to form a machinery part. The final steps include cleaning, inspection, and potential additional processes like heat treatment or final machining to meet machinery specifications.
Provide dimensions / size / tolerances / performance specifications of the item	See attachment for corresponding parts. A - 30.6 Kilograms B - 5.5 Kilograms C - 0.6 Kilograms
List required materials needed to make the product, including materials of product components, if applicable	Hadfield manganese (11-14% manganese steel)
Are there applicable certification requirements?	
Yes	
No	x
Please explain:	
Are there any applicable regulations that apply to the production of this item?	
Yes	
No	x
Please explain:	
Are there any other standards / requirements?	
Yes	
No	x
Please explain:	
Additional Comments:	
Additional technical comments:	If there is any relevant companies who are interested please email me in real time.
Volume and Pricing:	
Estimated Potential Business Volume (i.e. #units per day, month, year):	Quantity: 500-5,000 pieces
Estimated Target Price/Unit Cost Information:	n/a
Delivery Requirements:	
When is it needed by? (Immediate, 30 days, 6 months, etc.)	2-3 months
Describe packaging requirements (i.e. individually/group packaging, etc.)	n/a
Where will this item be shipped?	Illinois
Additional Comments:	
Is there other information you would like to include?	If there is any relevant companies who are interested please email me in real time.

[METRIC DIMENSIONS SHOWN IN BRACKETS]

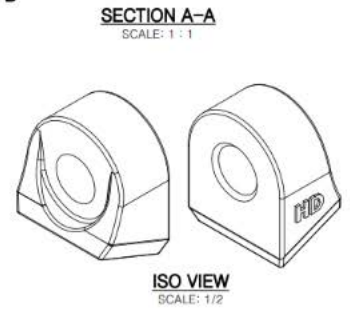
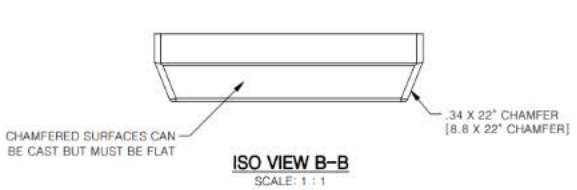
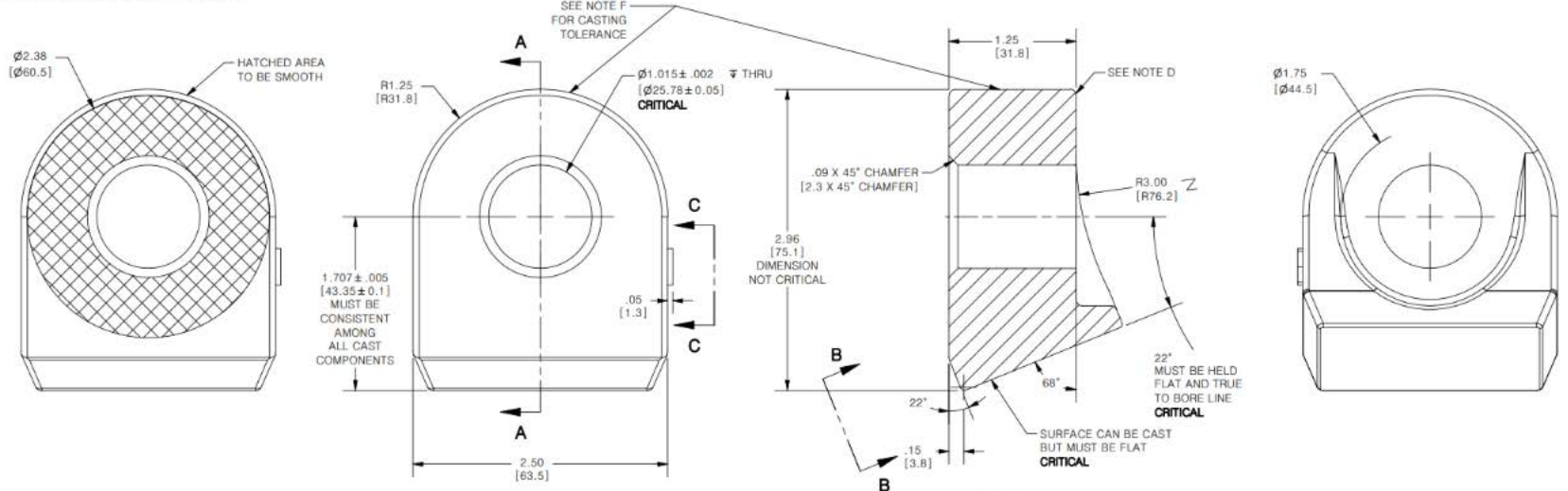

ONLY SHADED SURFACES SHOWN BELOW ARE ACCEPTABLE FOR GATING



- NOTE A: HADFIELD MANGANESE PER ASTM A128
- NOTE B: HARDNESS 348 - 415 HB (38 - 44 HRC)
- NOTE C: FINISH PLAIN WITH RUST INHIBITOR
- NOTE D: ALL EDGES RADIUS TO 0.0625" [1.5875mm] UNLESS OTHERWISE NOTED
- NOTE E: INVESTMENT CASTING IS THE PREFERRED METHOD OF PRODUCTION
- NOTE F: CAST COMPONENTS TO ISO 8082 CT 8

IF IN DOUBT, ASK!