

ITEM OPPORTUNITY SYNOPSIS

Scouting Number:	2024-078
Name of the item to be scouted:	Quoins
State item to be used in:	Vermont
Describe the Item:	
Please describe the item application/the end use of the item.	Looking for someone to be able to make the quoins as described in the attached drawing. This is for a Lock system, construction that needs to be in place for the boating season
Supplier Information:	
Type of Supplier Being Sought (select from the list below):	
Manufacturer	x
Contract Manufacturer	
Distributor	
Other (Please Specify)	
Reason for Scouting Submission (select from the list below)	
2nd Supplier	
Price	
Re-Shore	
Past supplier no longer available	x
New Product Startup	
BABA	
Other (Please Specify)	
Summary of Technical Specifications and Performance Requirements:	
Describe the manufacturing processes (elaborate to provide as much detail as possible)	Probably needs a CNC router 4'x8' --- the Southern Pine material has been procured already.
Provide dimensions / size / tolerances / performance specifications of the item	6 feet long, 9 inches wide, quoin for dock
List required materials needed to make the product, including materials of product components, if applicable	Southern Pine
Are there applicable certification requirements?	
Yes	
No	x
Please explain:	
Are there any applicable regulations that apply to the production of this item?	
Yes	
No	x
Please explain:	
Are there any other standards / requirements?	
Yes	
No	x
Please explain:	
Additional Comments:	
Additional technical comments:	
Volume and Pricing:	
Estimated Potential Business Volume (i.e. #units per day, month, year):	4 pieces
Estimated Target Price/Unit Cost Information:	based on availability
Delivery Requirements:	
When is it needed by? (Immediate, 30 days, 6 months, etc.)	April 2024
Describe packaging requirements (i.e. individually/group packaging, etc.)	protective
Where will this item be shipped?	Vermont
Additional Comments:	
Is there other information you would like to include?	

8 7 6 5 4 3 2 1

D
C
B
A

D
C
B
A

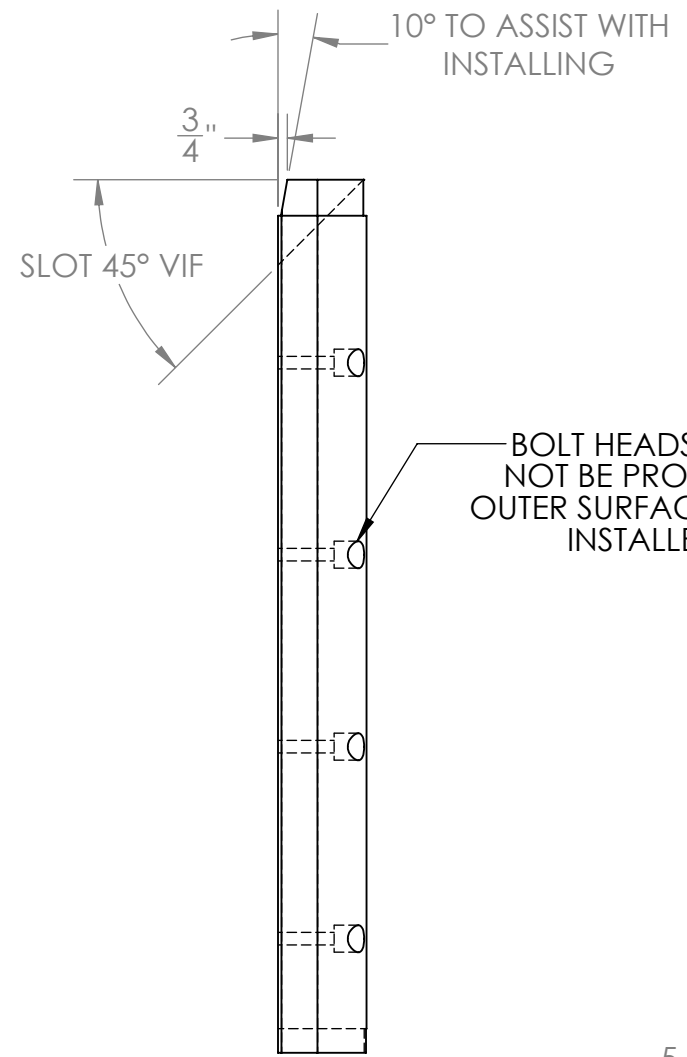

BOLT HEADS CAN NOT BE PROUD OF OUTER SURFACE ONCE INSTALLED

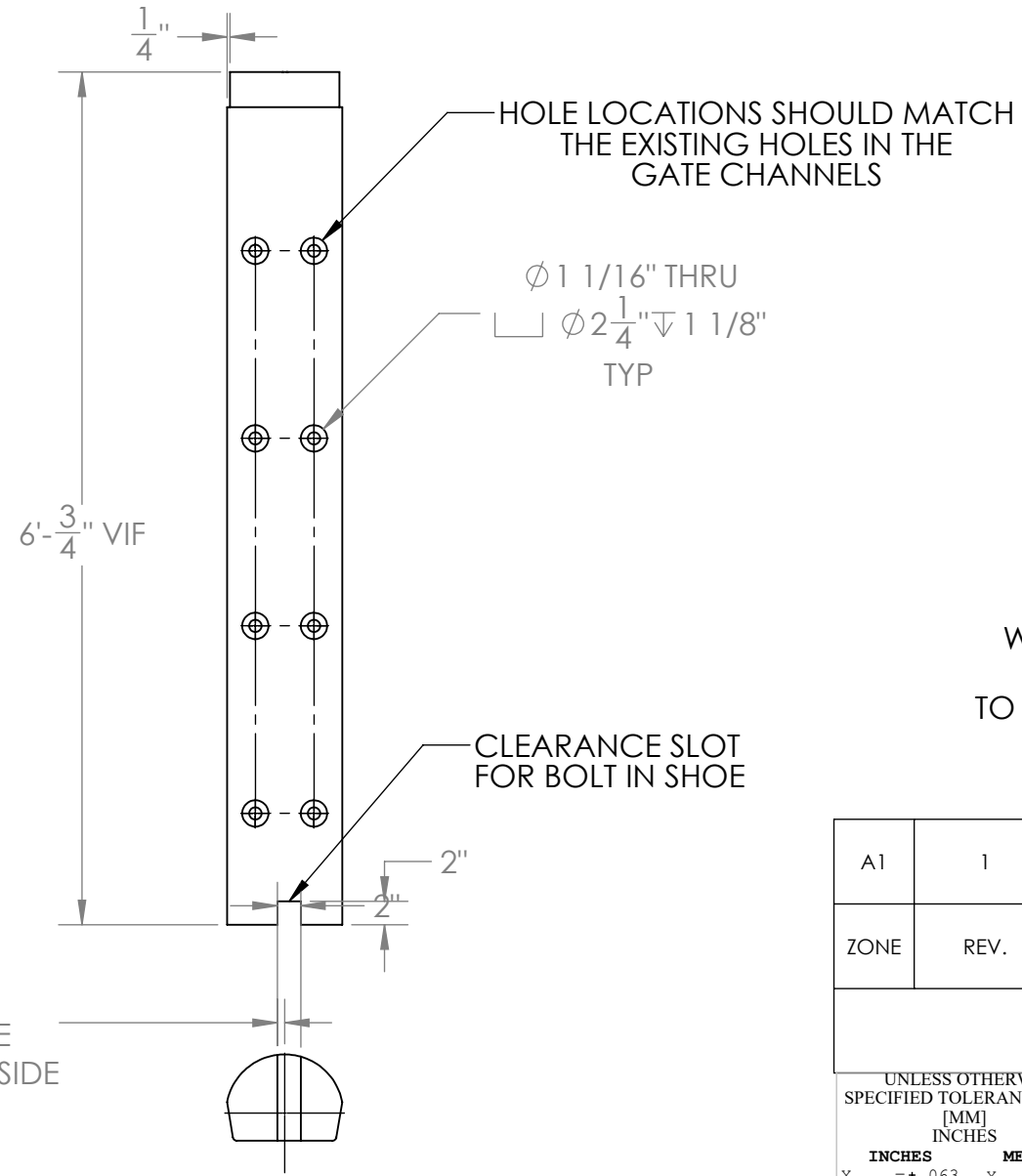
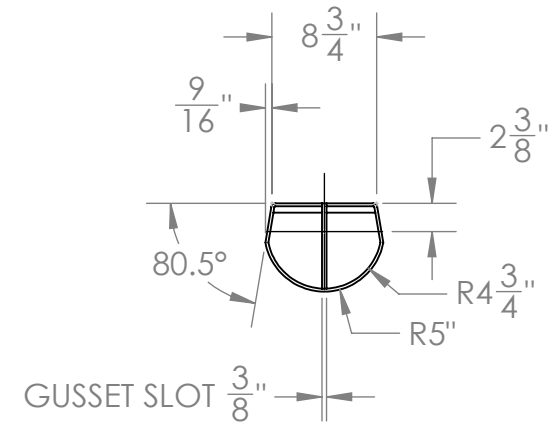

QUANTITY OF 4 REQUIRED
2 LEFT, 2 RIGHT

WOOD WILL BE SUPPLIED BY KINGSBURY

TO BE INSTALLED AFTER GATES ARE PAINTED

A1	1	MATERIAL REFERENCED TO S-001	Fri 03/22/2024	PJM
ZONE	REV.	DESCRIPTION	DATE	USER

REVISIONS				
UNLESS OTHERWISE SPECIFIED TOLERANCES ARE:	DATE	NAME	KINGSBURY COMPANIES LLC	
[MM]	02-19-2024	PJM	TITLE: Quoin Post	
INCHES				
INCHES			MATERIAL: SEE WOOD NOTES ON CONTRACT DRAWING S-001	
INCHES				
INCHES			FINISH	DWG. NO.
INCHES			MILL (NO PAINT)	1
INCHES				REV
INCHES				A
INCHES			SHEET 1 OF 1	

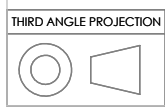

8 7 6 5 4 3 2 1