

ITEM OPPORTUNITY SYNOPSIS

Scouting Number:	2024-148
Name of the item to be scouted:	Autoclave Sterilizer System
State item to be used in:	Florida

Describe the Item:

<p>Please describe the item application/the end use of the item.</p>	<p>Gulf Ecosystem Measurement and Modeling Division (GEMMD) has requirement to sterilize laboratory materials including liquids to reduce exposure hazards to lab staff from environmental samples. These samples may include harmful algae, dinoflagellates, sewage-contaminated materials, etc. GEMMDs requirement is to purchase a ready to install and operate commercially available autoclave sterilizer that has local (Pensacola, FL) factory-authorized service and maintenance agreement.</p>
--	---

Supplier Information:

Type of Supplier Being Sought (select from the list below):	
Manufacturer	x
Contract Manufacturer	
Distributor	
Other (Please Specify)	
Reason for Scouting Submission (select from the list below)	
2nd Supplier	x
Price	
Re-Shore	
Past supplier no longer available	
New Product Startup	
BABA	
Other (Please Specify)	

Summary of Technical Specifications and Performance Requirements:

<p>Describe the manufacturing processes (elaborate to provide as much detail as possible)</p>	<p>Shell Assembly Two fabricated Type 316L stainless-steel shells, welded one within the other, form the sterilizer vessel. Type 316L stainlesssteel end frame(s) is welded to door end. On single door units, back of chamber is fitted with welded, 316L stainless-steel formed head. Sterilizer vessel is ASME rated at 50 psig (3.2 Bar) and insulated. The Vessel (for AMSCO 250LS only) includes one 1.0" (25 mm) NPT welded chamber bushing for Customer use. Steam-supply opening inside the chamber is shielded by a Type 316L stainless-steel baffle. Chamber Door(s) Door is constructed of a single formed piece of Type 316L stainless steel. Door is insulated to reduce the surface temperature of the stainless-steel door cover. During cycle operation, door is sealed by a steam-activated door seal. Door seal is constructed of a special long-life rubber compound. When sterilizer cycle is complete, the seal retracts under vacuum into a machined groove in sterilizer end frame. Door seal can be manually retracted to open the door and remove critical load in an emergency situation (if loss of vacuum or loss of power occurs). A handle is used to manually open (by lowering) and manually close (by raising) the door which is suspended by cables attached to a counterweight. A long-life proximity switch is used, by the control, to determine if the door is closed. An additional seal pressure switch prevents inadvertent cycle initiation if door is not sealed. The door assembly is equipped with a mechanical locking mechanism that ensures the door cannot be opened, as long as the seal is intact and energized, and more than 2.0 psi pressure is in the chamber. Door interlocks on double door sterilizers can be programmed to prevent inadvertent opening of door(s). Access code is required to override door interlocks</p>
---	--

Provide dimensions / size / tolerances / performance specifications of the item	Autoclave Sterilizer System similar in form and function to AMSCO 250LS – 20 x 20 x 38" (508 x 508 x 965 mm), 250L capacity
--	---

List required materials needed to make the product, including materials of product components, if applicable	See attached documentation
---	----------------------------

Are there applicable certification requirements?	
Yes	x

No	
Please explain:	UL Each sterilizer meets applicable requirements of the following listings and standards, and carries the appropriate symbols. • Governing Directives for Affixing the CE Mark: » Low-Voltage Directive (2014/35/EU) » EMC Directive (2014/30/EU) » Machinery Directive (2006/42/EEC) • Pressure Equipment Directive (PED): 97/23/EC. • UL/EN/CSA 61010-1: Safety Requirements for Electrical Equipment for Measurement, Control, and Laboratory Use Part 1: General Requirements • UL/EN/CSA 61010-2-040: Safety Requirements For Electrical Equipment For Measurement, Control, And Laboratory Use, Part 2-040: Particular Requirements For Sterilizers And Washer- Disinfectors Used To Treat Medical Materials • ASME Code, Section VIII, Division 1 for unfired pressure vessels. The pressure vessel is so stamped; ASME Form U-1 is furnished. The shell and door are constructed to withstand a working pressure of 45 psig (3.1 bar).
Are there any applicable regulations that apply to the production of this item?	
Yes	
No	x
Please explain:	
Are there any other standards / requirements?	
Yes	
No	x
Please explain:	
NAICS CODES:	
NAICS 1	6640
NAICS 2	
Additional Comments:	
Additional technical comments:	Please see attached documents
Volume and Pricing:	
Estimated Potential Business Volume (i.e. #units per day, month, year):	1 autoclave sterilizer is needed
Estimated Target Price/Unit Cost Information:	\$69,000.00
Delivery Requirements:	
When is it needed by? (Immediate, 30 days, 6 months, etc.)	1 month
Describe packaging requirements (i.e. individually/group packaging, etc.)	Delivered and installed at GEMMD facility, FOB
Where will this item be shipped?	US EPA Gulf Breeze, FL 32561-5299
Additional Comments:	
Is there other information you would like to include?	GEMMD is purchasing a new autoclave sterilizer to replace an older unit that does NOT have local service or parts available.

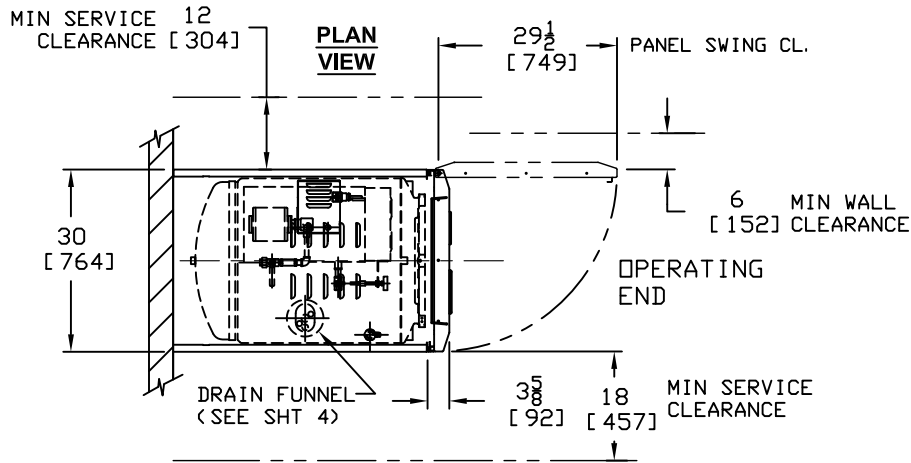

AMSCO 250LS			
GENERAL SPECIFICATIONS TABLE - Single Door / Electric Steam			
Physical Specifications			
Shipping Dimensions (North America)	W x H x L	38 x 81 x 53 in	1240 lbs / 562 kg
		965 x 2057 x 1346 mm	
Shipping Dimensions (International)	W x H x L	40 x 84 x 53 in	1382 lbs / 627 kg
		1016 x 2134 x 1346 mm	
Operating Information	W x H x L	30 x 74 1/2 x 45 1/8 in	1150 lbs / 522 kg
		762 x 1891 x 1146 mm	
	Full Load	1371 lbs / 622 kg	

Full load based on chamber fully loaded with water flasks.

250LS Heat Source	Heat Loss BTU/HR @ 71°F (21°C)						
	Single Door			Double Door			
	Cabinet	Recessed		Recessed One Wall		Recessed Two Walls	
	To Room	Front of Wall	Back of Wall	Front of Wall	Back of Wall	At each End	Btwn Walls
Bldg Steam	7000	2500	4500	2500	5300	2500	2800
Electric Gen.	8750	3300	5450	3300	6250	3300	2950

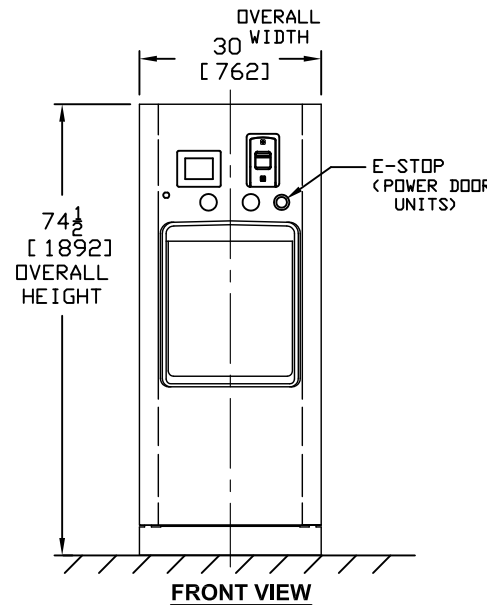
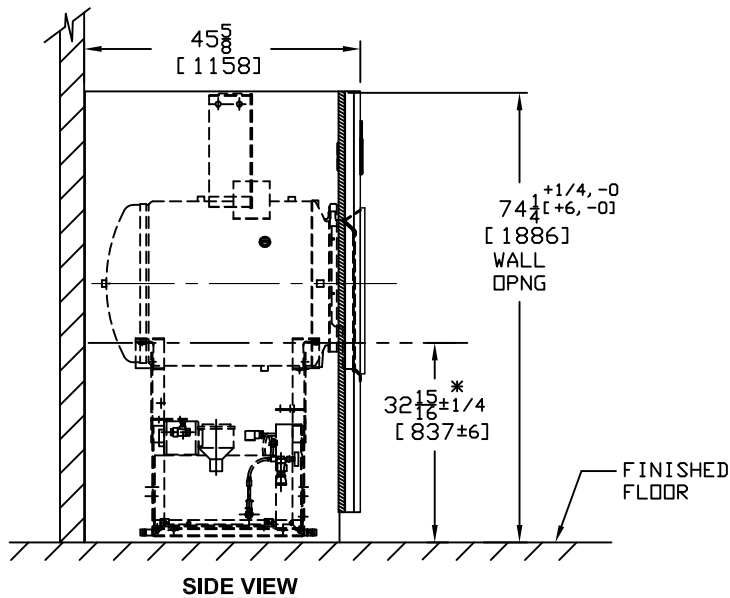

* INSTALL HEIGHT FOR LOADING CAR & TRANSFER CARRIAGE. MEASUREMENT TO BOTTOM OF CHAMBER OPENING.

SHT. 1 OF 4

ALL DIMENSIONS ARE IN INCHES (MILLIMETERS)		AMSCO 250LS SERIES STERILIZER 20x20x38 (508x508x965) VACAMATIC OR GRAVITY SINGLE DOOR, CABINET, ELECTRIC STEAM GENERATOR	EQUIPMENT DRAWING NO. 387362-162
ALSO REFER TO GENERAL NOTES APPLICABLE TO EQUIPMENT DRAWINGS			
DWG. NO. 62941-091		ITEM _____	
STERIS® STERIS Corporation Mentor, OH		LOCATION(S) _____	

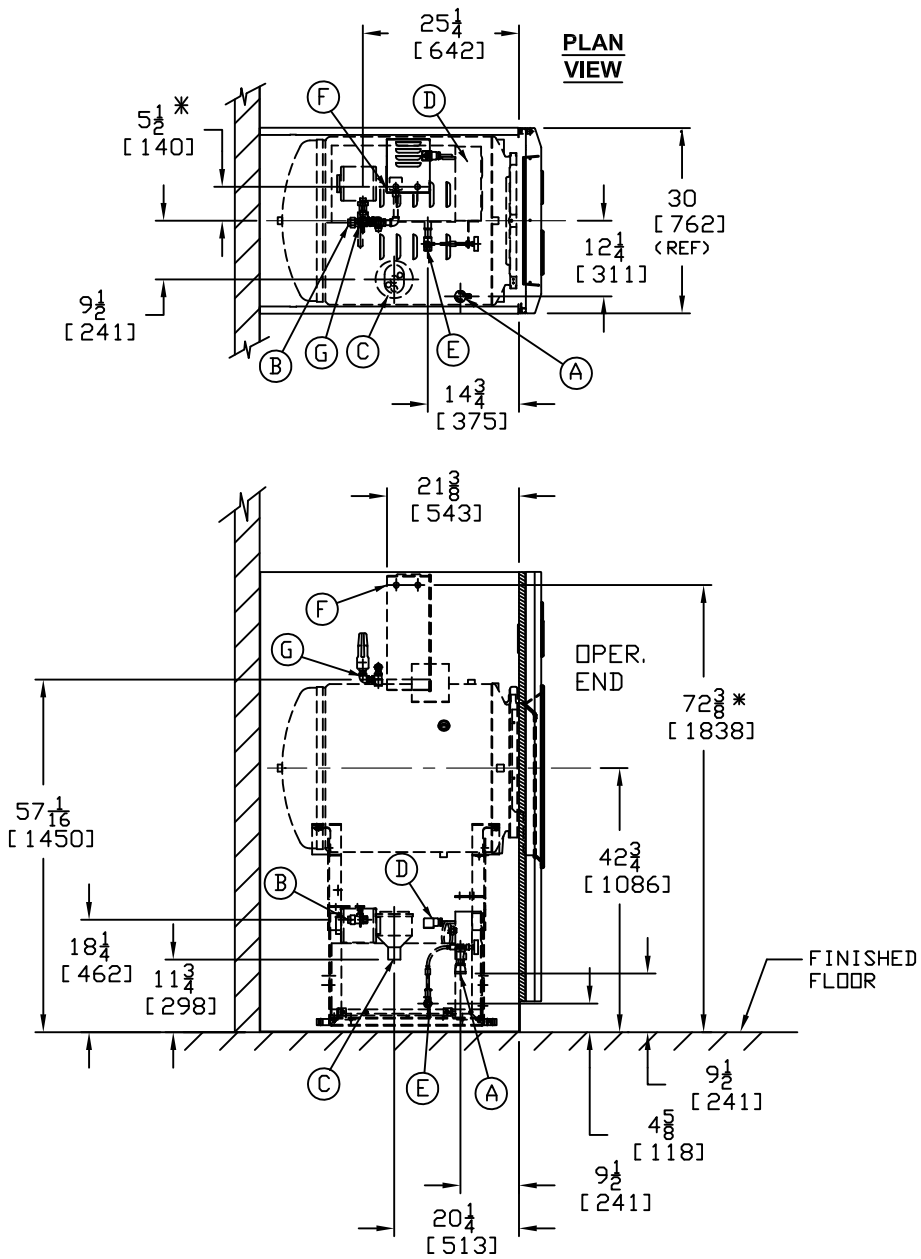

* TO CENTERLINE OF 7/8 KNOCKOUT ON CONTROL BOX.

SIDE VIEW

AMSCO 250LS Plumbing Utility Requirements (Electric Steam Generator)			
Code	Utility	Parameter	Requirement
A	Cold Water (Common properties)	Connection Size / Type	1" NPT
		Water Quality	See Feed Water Quality Table
		Temperature Range	40° - 70°F / 10°C - 21°C
	Cold Water (Water Ejector)	Dynamic Pressure	30-50 (psig) / 206.8 - 344.7 (kPa)
		In Cycle Consumption*	66 Gal / 250 Lit (per cycle)
		Out of Cycle Consumption	2 Gal / 7.5 Lit (per hour)
	Peak Capacity (in cycle)	6 Gal / 22.7 Lit (per minute)	
B	Hot Water (Steam Generator)	Connection Size / Type	1/2" NPT
		Water Quality	See Feed Water Quality Table
		Dynamic Pressure	20-50 (psig) / 137.9 - 344.7 (kPa)
		In Cycle Consumption*	4 Gal / cycle
		Out of Cycle Consumption	1 Gal / 3.8 Lit (per hour)
	Peak Capacity (in cycle)	1 Gal / 3.8 Lit (per minute)	
C	Drain / Floor Sink	Connection Size / Type	1 1/2" ODT
		Operation Flow Rate	6 Gal / 22.7 Lit (per minute)
		Floor Sink	12 x 12 in (305x305mm) Min Size
E	Drain - Steam Gen	Connection Size / Type	1/2" ODT
G	Safety Relief Valve	Connection Size / Type	3/4" NPT
		Pressure	50 psig
		Capacity	374 lbs/hr

* Water usage based on 30 minutes exposure and 5 minute dry @121°C. Actual consumption may increase depending on load volume.

Electrical Requirements: Sterilizer with Steam Generator				
Code	Description	Voltage	Hz	Amps / phase
F	Control Box	120, 1 Ph	50/60	9.5
D	Electric Service for Steam Generator	208, 3 Ph	50/60	83.2
		240, 3 Ph	50/60	72.2
		380/415, 3 Ph	50/60	38/42
		440/480, 3 Ph	50/60	31/37
		575/600, 3 Ph	50/60	28/29

ALL DIMENSIONS ARE IN INCHES (MILLIMETERS) ALSO REFER TO GENERAL NOTES APPLICABLE TO EQUIPMENT DRAWINGS DWG. NO. 62941-091 STERIS STERIS Corporation Mentor, OH	AMSCO 250LS SERIES STERILIZER 20x20x38 (508x508x965) VACAMATIC OR GRAVITY SINGLE DOOR, CABINET, ELECTRIC STEAM GENERATOR	EQUIPMENT DRAWING NO. 387362-162
		ITEM _____ LOCATION(S) _____

Recommended Cold Water Feed for Sterilizers		
Condition	Nominal Conditions	Maximum Conditions
Temperature	40°- 60°F (4°- 16°C)	70°F (21°C)
Total Hardness as CaCo ₃	50 - 120 mg / L	171 mg / L
Total Dissolved Solids	100 - 200 mg / L	500 mg / L
Total Alkalinity as CaCo ₃	70 - 120 mg / L	180 mg / L
pH Level	6.8 - 7.5	6.5 - 8.5
Total Silica	0.1 - 1.0 mg / L	2.5 mg / L
<i>17.1 mg / L = 1 Grain Hardness</i>		

Recommended Hot Water Feed for Carbon Steel Steam Generators		
Condition	Nominal Conditions	Maximum Conditions
Temperature	70°- 140°F (21°- 60°C)	150°F (66°C)
Total Hardness as CaCo ₃	0 - 17 mg / L	130 mg / L
Total Dissolved Solids	50 - 150 mg / L	250 mg / L
Total Alkalinity as CaCo ₃	50 - 150 mg / L	180 mg / L
pH Level	6.8 - 7.5	6.5 - 8.5
Total Silica	0.1 - 1.0 mg / L	2.5 mg / L
Resistivity	2000-6000	26,000
<i>17.1 mg / L = 1 Grain Hardness</i>		

NOTES:	
1.	For general installation information, see STERIS drawing No. 62941-091 (This drawing should always accompany the equipment drawings.) If drawing # 62941-091 is not attached, contact STERIS Service Engineering at 1-800-999-4004 to obtain a copy.
2.	If loading car and transfer carriage are to be used, front clearance should equal twice the length of the sterilizer. Floors should be level in front of the sterilizer door.
3.	Leveling feet are provided for proper installation.
4.	The SEISMIC anchorage of this sterilizer has been pre-approved in California. Contact Service Engineering at 1-800-333-8848 to obtain a copy of the latest SEISMIC anchorage report.
5.	For seismic installations, a seismic add-on kit (Ref P10050030) must be installed on the sterilizer.
6.	STERIS assumes no responsibility for changes made necessary through failure to observe these specifications on equipment drawing and note pages. Specifications and descriptions are subject to change without notice.
7.	Utility connections should be within 6 feet of sterilizer for installation. Shut off valves should be visible and accessible.
8.	Safety relief valve is piped to within a foot of the floor as standard. Code G is the location of the safety relief valve . 3/4" NPT, 374 lb/hr, Set Point is 50 psig. If building code requires piping to atmosphere, piping is by others.
9.	The sterilizer is not supplied with a vacuum breaker or backflow preventer and, where required by local codes, installation of such a device in waterline is by others.

ALL DIMENSIONS ARE IN INCHES (MILLIMETERS) ALSO REFER TO GENERAL NOTES APPLICABLE TO EQUIPMENT DRAWINGS DWG. NO. 62941-091 	AMSCO 250LS SERIES STERILIZER 20x20x38 (508x508x965) VACAMATIC OR GRAVITY SINGLE DOOR, CABINET, ELECTRIC STEAM GENERATOR	EQUIPMENT DRAWING NO. 387362-162
		ITEM _____ LOCATION(S) _____

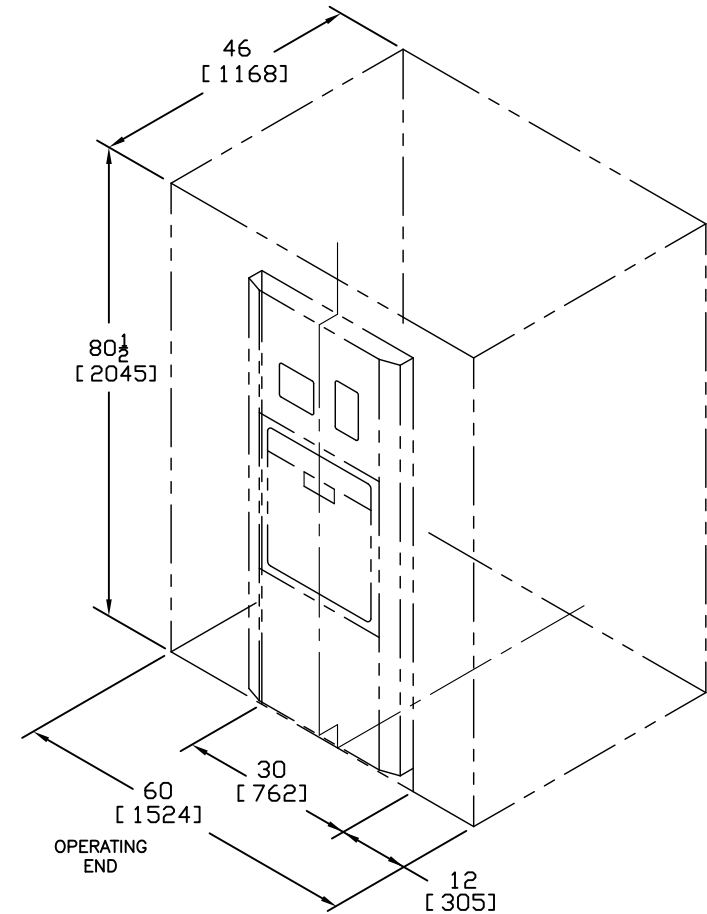
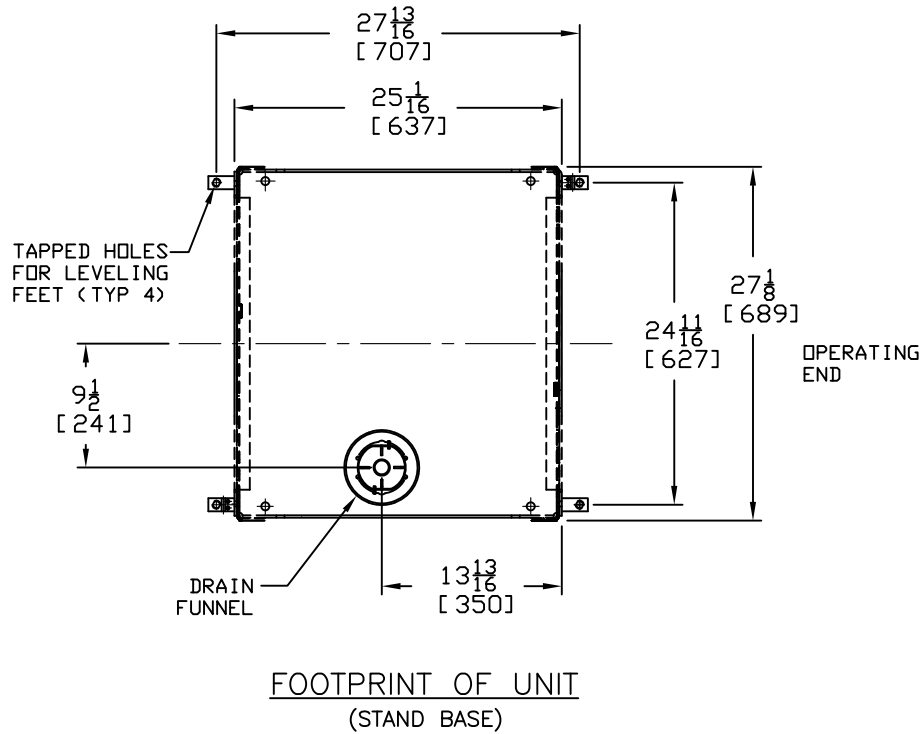

SPACE AVAILABILITY

THIS DRAWING SHOWS THE OVERALL SPACE NEEDED (INCLUDING SERVICE CLEARANCES), TO BE FREE OF BUILDING OBSTRUCTIONS FOR THIS INSTALLATION.

SHT. 4 OF 4

ALL DIMENSIONS ARE IN INCHES (MILLIMETERS) ALSO REFER TO GENERAL NOTES APPLICABLE TO EQUIPMENT DRAWINGS DWG. NO. 62941-091		AMSCO 250LS SERIES STERILIZER 20x20x38 (508x508x965) VACAMATIC OR GRAVITY SINGLE DOOR, CABINET, ELECTRIC STEAM GENERATOR	EQUIPMENT DRAWING NO. 387362-162 ITEM _____ LOCATION(S) _____
STERIS Corporation Mentor, OH			

APPLICATION

AMSCO 110LS and AMSCO 250LS Small Sterilizers are designed for use in laboratory and industrial applications. Each is configured with pre-vacuum, liquid, and gravity cycles. A full list of standard and optional cycles begins on page 2.

DESCRIPTION

AMSCO 110LS and AMSCO 250LS Small Sterilizers for life science applications are the next advancement in the STERIS line of steam-jacketed sterilizers. Both sterilizers are equipped with the latest features in state of the art technology and ease of use.

Interior Chamber Dimensions

- **AMSCO 110LS** – 16 x 16 x 26" (406 x 406 x 660 mm), 110L capacity
- **AMSCO 250LS** – 20 x 20 x 38" (508 x 508 x 965 mm), 250L capacity

Allen-Bradley MicroLogix™ Control System with enhanced functionality and user-friendly Allen-Bradley PanelView Plus™ 7 700 interface screen.*

- Touch-sensitive screen with 18-bit color graphic display
- Display features 640 x 480 resolution color-active matrix



(Typical - details may vary.)

Selections Checked Below Apply To This Equipment

MODEL/CHAMBER SIZE (W x H x L)

- AMSCO 110LS**
16 x 16 x 26" (406 x 406 x 660 mm)
 Prevacuum (LV-110) Isothermal (LI-110)
- AMSCO 250LS**
20 x 20 x 38" (508 x 508 x 965 mm)
 Prevacuum (LV-250) Isothermal (LI-250)

STEAM SOURCE

- Building Steam
- Stand Alone Electric Steam Generator
 STERIS Provided Customer Provided
- Integral Electric Steam Generator¹
 Carbon Steel Stainless Steel
Voltage Options
 - 208 Volt, 60 Hz
 - 240 Volt, 60 Hz
 - 400 Volt, 50 Hz
 - 480 Volt, 60 Hz
 - 600 Volt, 60 Hz
- Integral Indirect Stainless-Steel Clean Steam Generator (SD589)¹⁰

SINGLE DOOR

- Cabinet Enclosed/Freestanding
- Recessed

DOUBLE DOOR

- Recessed through One Wall
- Sterile side Non-sterile side
- Recessed through Two Walls²

OPTIONS

- Power Door(s)
- Liquid Air Cool (w/vacuum)

- Effluent Decontamination Cycle
- Pure Steam Piping to Chamber
- Air Detector System
- Reference Recorder
- Printer on Both Ends⁸
- Bioseal³
- RTD Load Probe(s) and F₀ Sterilization
 - One Probe Two Probes (max. 2)
- Drain Line Reference Probe
- Air-Differential Seal (NOE) for Double Door Units
- Back Panel for Single Door Cabinet Enclosed Unit
- 1" Chamber Penetration, Qty. 1 (AMSCO 110LS only)⁴
- One Additional Chamber Penetration (AMSCO 250LS)⁴
- Vacuum Pump⁵
 - 120 V, 1-Ph / 208 / 240 Vac, 3-Ph
 - 120 V, 1 Ph / 240 Vac 3-Ph
 - 120 V, 1-Ph / 480 Vac, 3-Ph
 - 120 V, 1-Ph / 600 Vac, 3-Ph
 - 230 V, 1 Ph / 400 Vac, 3-Ph (International)
 - Other - Specify _____
- Dry Contacts
- Backflow Preventer
- Auto Flush for Steam Generator
- 0.2 Micron Bacterial Retentive Filter
- Green Gravity Water Saver System
- STERI-GREEN® Water Conservation System
- STERI-GREEN PLUS® Water Conservation System (Chilled water required)

ACCESSORIES (for AMSCO 110LS)⁶

- One Intermediate Shelf (16 x 16 x 26")
- Air Compressor, Portable, 115 Vac

ACCESSORIES (for AMSCO 250LS)

- One Intermediate Shelf (20 x 20 x 38")
- Seismic Tie-Down Kit^{7,9}
- Air Compressor, Portable, 115 Vac
- Loading Rack and Two Shelves (20 x 20 x 38")
 - Single Door Double Door
- Loading Car
- Transfer Carriage
- Chamber Track Assembly
 - Single Door Double Door
- Loading Car, Transfer Carriage & Chamber Track Assembly
 - Single Door Double Door

Notes:

1. AMSCO 110LS double door sterilizers are not available with integral electric steam generator.
2. Available for AMSCO 250LS double door sterilizers only. Contact engineering if mounting through two walls is required for AMSCO 110LS.
3. Available on AMSCO 250LS double manual door sterilizers only.
4. One chamber penetration is standard on AMSCO 250LS.
5. 1-Ph is for control, 3-Ph is for pump motor
6. Loading rack & 2 shelves standard on AMSCO 110LS.
7. Based on CA requirements.
8. Printer at operating end is standard. Option adds additional printer to non-operating end.
9. Units with Bioseal require special seismic kit.
10. Integral indirect clean steam generator requires field certification for UL/CSA.

Item _____

Location(s) _____

* Allen-Bradley MicroLogix™ and Allen-Bradley PanelView Plus™ are registered trademarks of Rockwell Automation, Inc.

- Display is designed with emphasis on human factors and user recognizable symbols.
- Noise level for units with water ejector 68DbA, units with vacuum pump 74DbA.

Cycle Programming and Flash Memory

- **20 cycles** may be individually selected and programmed
- Help screens for control operation
- Program permanently stored in flash memory
- Variables permanently stored in flash memory

Vertical Sliding Door(s)

AMSCO LS configurations include choice of single or double door sterilizers and open or recessed mounting. The doors are manually operated. Door seals (1 per door) are non-lubricated, steam activated.

NOTE: Recess two wall mounting is not available for AMSCO 110LS double door sterilizers.

Modularized Vessel And Piping

Vessel and piping are designed for increased dependability and reduced service time.

- Reduced piping components increase reliability
- Vessel design allows higher operating temperature of 141°C (285°F)
- Non-clogging chamber drain line prevents media from plugging drain line
- Emergency manual exhaust valve

STANDARDS

Each sterilizer meets applicable requirements of the following listings and standards, and carries the appropriate symbols.

• Governing Directives for Affixing the CE Mark:

- › Low-Voltage Directive (2014/35/EU)
- › EMC Directive (2014/30/EU)
- › Machinery Directive (2006/42/EEC)

• Pressure Equipment Directive (PED): 97/23/EC.

• **UL/EN/CSA 61010-1:** Safety Requirements for Electrical Equipment for Measurement, Control, and Laboratory Use Part 1: General Requirements

• **UL/EN/CSA 61010-2-040:** Safety Requirements For Electrical Equipment For Measurement, Control, And Laboratory Use, Part 2-040: Particular Requirements For Sterilizers And Washer-Disinfectors Used To Treat Medical Materials

• **ASME Code, Section VIII, Division 1** for unfired pressure vessels. The pressure vessel is so stamped; ASME Form U-1 is furnished. The shell and door are constructed to withstand a working pressure of 45 psig (3.1 bar).

CYCLE DESCRIPTIONS

Standard and optional cycles are as follows:

Gravity Cycle (standard) provided on prevacuum, and isothermal sterilizers, for sterilization of heat- and moisture-stable goods at 100°C to 141°C (212°F to 285°F), and decontamination of bagged non bio-hazardous laboratory wastes. Gravity cycle utilizes gravity air-displacement principle. However, the gravity cycle has a standard drying phase which uses a vacuum. The drying phase can be disabled.

Liquid Cycle (standard) provided on prevacuum, and isothermal sterilizers, for sterilization of liquids and media in vented borosilicate glass or metal containers at 100°C to 141°C (212°F to 285°F). Liquid cycle uses optimal solution cooling feature, during exhaust (cooling) phase, to control exhaust rate.

Prevacuum Cycle (standard) provided only on prevacuum sterilizer, for efficient, high-volume sterilization of porous, heat- and moisture-stable materials at 100°C to 141°C (212°F to 285°F). Prevacuum cycle utilizes a mechanical air-evacuation system.

USP 660 Cycle (standard) developed to assist meeting the requirements of USP 660 sterilization test cycle for glassware. Load probe option is recommended when using this USP cycle.

Continuous Cycle (standard) This cycle allows for up to 9,999 cycles to be run consecutively without the need of an operator. Cycle parameters can be set, along with the amount of time to lapse in between cycles. For this cycle to function, a power door is required to facilitate automatic opening and closing.

Waste Bag Cycle (standard) This cycle has been preconfigured with cycle parameters shown to be effective when processing lab waste in autoclavable bags. Through air removal assistance and a controlled exhaust, the internal temperature is increased more effectively and faster, while minimizing boil over of any liquids present. Parameters may need to be adjusted based on specific loads. Bags should not be completely sealed.

Isothermal Cycle (optional) provided only on isothermal sterilizer, for processing of heat-sensitive and heat-coagulable solutions in vented borosilicate glass or metal containers at 78°C to 110°C (170°F to 230°F). Isothermal cycle utilizes steam to enhance temperature control and prevent layering of steam and air within the chamber. Process maintains positive pressure in chamber to inhibit media boiling.

NOTE: Temperature control spread is greater on Isothermal units ±6°C.

Liquid Air Cool (Optional) provides water to jacket, and air pressure to chamber to improve exhaust time for liquid loads, and to reduce boil-over.

ATF 1 and ATF 2 Cycles (Alternating Tangential Flow) are designed to sterilize the XCell™ ATF system. These can be used for other purposes that require rates and hold times in the pre-conditioning pulses and a cool down in exhaust by temperature.

Effluent Decontamination Cycle (Optional) is used for processing contaminated laboratory waste (BL-3 and BL-4). Condensate produced during processing cycle is decontaminated before discharge to floor drain. Steam is admitted through bottom of sterilizer chamber, and chamber is exhausted out top side of vessel. During purge and vacuum pulses, all purge and exhaust gases are vented through a 0.2 micron bacterial retentive filter. Filter housing is steam jacketed to prevent wetting of filter membrane. Available with fast exhaust or optimal solution cooling (slow exhaust) exhaust types. User is responsible for development of process parameters.

Leak Test Cycle, for verification of door seal and piping system integrity. Cycle parameters are pre-programmed and fixed. Acceptable maximum leak rate is 1.0 mm Hg/minute over a 10-minute period following a fixed stabilization time.

Daily Air Removal Test (Dart) Cycle, provided only on prevacuam sterilizer, for verification of effective removal of residual air in chamber and load during testing. Test cycle determines if even and rapid steam penetration into test load occurred. Cycle parameters are preprogrammed and fixed.

Bowie-Dick Test is available for 121°C (250°F) and 132°C (270°F) prevacuam cycles.

Healthcare Cycles - The LS Series sterilizers can be programmed to reproduce cycles that are used for healthcare applications, however, these sterilizers do not have FDA clearance and cannot be used for patient treatment applications

ENVIRONMENTAL SUSTAINABILITY

Automatic Utilities Startup/Shutdown

This feature permits slow cooling of the entire vessel and load. Shutdown may be programmed to activate at the end of any designated cycle or time of day. When activated, control system automatically shuts off all utility valves, conserving steam and water usage. Sterilizer utilities can be restarted either by programmed time or manual operation. A different shutdown and restart time can be programmed for each day.

Green Mode

The Green Mode is a standard feature on the control that will shut off the steam to the jacket after the unit has sat idle for a specified period of time. The specific time frame is determined by the user and entered into the control during set up; it can be changed at any time.

Green Gravity Water Saver System

The Green Gravity Water Saver System provides additional water savings by collecting steam effluent and holding it in a cooling tank, reducing the amount of water required to cool the effluent.

STERI-GREEN® Water Conservation System

This system significantly reduces the consumption of potable water. The STERI-GREEN system utilizes a mixing tank and an air-cooled heat exchanger to cool and recycle vacuum pump water and steam effluent. Water temperature is constantly monitored to minimize the need to add fresh cool water to the mixing tank. The system can provide up to 79% water savings over the vacuum pump alone, or up to 87% over a water ejector. When ordered, system includes a vacuum pump (3-phase power required).

STERI-GREEN PLUS® Water Conservation System

The STERI-GREEN PLUS system utilizes facility chilled water supply. The system utilizes a mixing tank and a series of heat exchangers, integrated with the a chilled water loop, to cool and recycle vacuum pump water and effluent. Water temperature is constantly monitored to minimize the need to add fresh cool water to the mixing tank. This system provides up to 99% water savings over water ejector or vacuum pump upgrade alone. When ordered, system includes a vacuum pump (3-phase power required).

STANDARD FEATURES

Hinged front cabinet panel opens for convenient access to sterilizer piping and control system.

Resistance Temperature Detectors (RTDs) are installed for sterilizer temperature control. The chamber drain line RTD senses and controls temperature variations within the sterilizer chamber. A jacket RTD provides temperature control within the jacket space. These RTD signals, converted into electrical impulses, provide accurate control inputs and readouts throughout entire cycle.

Software calibration is provided for all temperature and pressure inputs. Calibration is performed in the service mode, accessible through the touch screen displays, and accomplished using external or internal temperature and pressure sources. Control system provides a printed record of all calibration data for verification to current readings.

Cycle Data Records, recorded on the printer tape. They can also be retrieved for on-screen review, USB, or sent via e-mail if the system is enabled. The e-mail feature requires a network connection.

Optimal solution cooling is designed to safely cool various liquids in vented, borosilicate glass containers with minimum liquid loss due to boil-over, and to keep normal evaporation loss below 5%. Optimal solution cooling is an integral part of the factory-programmed liquid cycle. During the exhaust (cooling) phase, the control utilizes this feature to optimize the exhaust rate regardless of load size or container fill volume, up to one liter. During cooling, the initial rate, initial rate transition point, as well as the second rate and final vacuum level are adjustable.

Steam purge feature is provided to assist in air removal and preheat the load.

Automatic steam shutoff to jacket is provided for isothermal and liquid cycles. When activated for isothermal cycles, the jacket control conducts a timed jacket drain, automatically allowing for the operation of cycles at lower temperatures. When activated for liquid cycles, steam supply to the jacket is turned off during exhaust phase, allowing load to cool more efficiently.

Insulation, one-inch thick, asbestos-free spin-glass (rated at 1000 °F [538 °C] continuous) encompasses the exterior of the sterilizer vessel and is sealed in an oil and water resistant outer jacket.

Lighted DIN connectors are installed on all steam, water, and exhaust valves for reliability and ease of maintenance.

Air Backup to seals is provided on all double door sterilizers, with either bioseal or air differential seals.

Visible Gauges are standard. Chamber and jacket pressure gauges are standard on the operating end and non-operating end.

CONTROL SYSTEM

Design Features

Together, the Allen-Bradley MicroLogix™ PLC control and PanelView Plus™ 7 700 display, monitor and control all sterilizer operations and functions. Control system is factory-programmed with standard sterilizing cycles, each adjustable to meet specific processing requirements. All control configuring is performed through touch screen displays.

Cycle values and operating features may be adjusted and verified prior to cycle operation. Once cycle is started, cycles and cycle values cannot be changed until cycle is complete. On completion of cycle, timers reset to the previously selected values, eliminating the need to reset values between repeated

cycles. If chamber temperature drops below the under temperature setting during the exposure phase, timer can be set to stop and automatically reset or resume once normal operating temperature is reached.

Critical control system components are housed within a sealed compartment to protect components from moisture and heat generated during sterilization process.

The control system is provided with features such as audit trail, password management and electronic signatures, which can



Typical Cycle Menu Display

facilitate compliance to 21 CFR Part 11 (Code of Federal Regulations Title 21)

Operator interface control panel, consisting of touch screen and thermal printer, is located on operating (load or nonsterile) end of sterilizer. If the sterilizer is equipped with double doors, an additional touch screen is provided on the non-operating (unload or sterile) end.

- **Touch-Sensitive Screen** features a color active matrix 18-bit graphics display. All sterilizer functions, including cycle initiation and cycle configuration, are operated by pressing the touch-sensitive areas on the display, referred to as buttons. Display indicates appropriate control buttons, operator prompts and status messages necessary to assist in sterilizer operation. All displayed messages are complete phrases with no codes to be cross-referenced. Display also indicates any abnormal conditions that may exist either in or out of a cycle.
- **Thermal printer** is a high resolution (8 dots per mm) printer. It is fast and quiet, printing at 25 lines per minute on industrial grade thermal paper. The device provides an easy-to-read printed record of all pertinent cycle data on 2.25" (57 mm) wide paper. Data is automatically printed at the beginning and end of each cycle and at transition points during the cycle. Three paper tape rolls are furnished with each unit. Printouts have a guaranteed lifetime of 25 years and are resistant from exposure to steam, alcohol, UV and visible light, oil, heat and water.
- **Non-operating end (NOE) control panel** (equipped on double-door sterilizers only) includes a touch-sensitive screen similar to the operating end screen. Preprogrammed cycles can be started from the NOE control panel. Display concurrently shows the same information as the operating end screen display.
- **Cycle configuration** is performed by accessing the **change values** menu on either end of a double door sterilizer. Utility shutdown parameters can only be changed on the OE

display. In addition to adjustment of cycle values, the following operating parameters can also be changed through the change values menu:

- » **Time Display and Printout Units** in standard AM/PM or 24-hour military (MIL) time.
- » **Selectable Cycle Name** permits user to name each cycle with any combination of letters, numbers, blank spaces, and underscores, up to eight characters long.
- » **Print Interval** permits adjustment of the time period between cycle-status printouts generated during the sterilize phase.
- » **Security access code** is required to enter the operating mode (running cycles), supervisor mode (changing values), and service mode. Operating the sterilizer or accessing change values menu causes display to request the entry of an access code. If access code is not properly entered, display returns to the standby screen, denying user access to the sterilizer or programming. Access to the sterilizer can be limited to 12 operators, each with a different access code.
- » **Alarm tones** – The end of cycle and alarm tones have adjustable volumes ranging from off, low, medium and high. The alarm tone does not have the selection for off. Touching the display buttons will create audible beep.
- » **Temperature Display and Printout Units** in Celsius (°C) or Fahrenheit (°F). Temperature is set, displayed, controlled, and printed to the nearest 0.1°. Recalibration is not required when changing temperature units from °C to °F and vice versa.
- » **Pressure/Vacuum Display and Printout Units** in psi/In/Hg, Bar (Gauge and Absolute). Recalibration is not required when changing pressure units.

Mobile and PC Messaging (Standard)

This is a standard feature on the control that allows the user to receive text messages or emails alerts regarding the status of the autoclave. The operator can choose from a list of # possible alerts from which to be notified.

SCADA Ready Control Interface (Standard)

If requested, STERIS can provide the user the information to allow communication between the autoclave and the Building Management System. An ethernet connection is required.

Printer Data Storage (Standard)

All printer data is saved internally and can be retrieved and viewed on the display screen, exported to a USB drive or emailed to the User.

Cycle usage (Standard)

Utilization of the sterilizer can be monitored for each User, data can be exported via an Ethernet or USB port.

SAFETY FEATURES

Control lockout switch (equipped on chamber door) senses when door seal is energized and tight against the door. Control prevents cycle from starting until the limit switch signal is received. If control loses appropriate signal during cycle, alarm activates, cycle aborts, and chamber safely vents with a controlled exhaust.

Chamber float switch activates alarm, aborts cycle, and safely vents chamber with a controlled exhaust if excessive condensate is detected in the vessel chamber.

Door interlocks (double door units only) allow only one door to be opened at a time and, during processing, prevent the non-operating end (NOE) door from being opened until a satisfactory cycle is complete. If a cycle is aborted, the NOE door cannot be opened. The use of this feature may affect the door gaskets life expectancy unless an air differential or bio seal is provided.

Pressure relief valve limits the amount of pressure buildup so that the rated pressure in the vessel is not exceeded.

Emergency stop button (located on front of the sterilizer) is included on all sterilizers. A key is required to release the emergency stop (once pushed) before the unit can return to normal operation.

CONSTRUCTION

Shell Assembly

Two fabricated Type 316L stainless-steel shells, welded one within the other, form the sterilizer vessel. Type 316L stainless-steel end frame(s) is welded to door end. On single door units, back of chamber is fitted with welded, 316L stainless-steel formed head.

Sterilizer vessel is ASME rated at 50 psig (3.2 Bar) and insulated. The Vessel (for AMSCO 250LS only) includes one 1.0" (25 mm) NPT welded chamber bushing for Customer use.

Steam-supply opening inside the chamber is shielded by a Type 316L stainless-steel baffle.

Chamber Door(s)

Door is constructed of a single formed piece of Type 316L stainless steel. Door is insulated to reduce the surface temperature of the stainless-steel door cover.

During cycle operation, door is sealed by a **steam-activated door seal**. Door seal is constructed of a special long-life rubber compound. When sterilizer cycle is complete, the seal retracts under vacuum into a machined groove in sterilizer end frame. Door seal can be manually retracted to open the door and remove critical load in an emergency situation (if loss of vacuum or loss of power occurs).

A handle is used to manually open (by lowering) and manually close (by raising) the door which is suspended by cables attached to a counterweight.

A long-life proximity switch is used, by the control, to determine if the door is closed. An additional seal pressure switch prevents inadvertent cycle initiation if door is not sealed.

The door assembly is equipped with a mechanical locking mechanism that ensures the door cannot be opened, as long as the seal is intact and energized, and more than 2.0 psi pressure is in the chamber. Door interlocks on double door sterilizers can be programmed to prevent inadvertent opening of door(s). Access code is required to override door interlocks.

NOTE: Bio-Seal option is available for AMSCO 250LS, double manual door sterilizers, as discussed on page 5.

Chamber Drain System

Drain system is designed to prevent pollutants from entering

into the water-supply system and sterilizer. An optional backflow preventer is available. Water supply shutoff valve is located behind the front cabinet service panel under the chamber.

Automatic Drain Effluent Cooling

The piping system to the drain provides automatic condensing of chamber steam and disposal of condensate to waste.

Cooling water is added to ensure discharge temperature is discharged at or below 60°C (140°F). A separate resistance temperature detector (RTD) is included to limit the volume of water to only the amount required to achieve target temperature, thus conserving water.

Vacuum System

Chamber pressure is reduced during the conditioning phase and drying phase through the means of either a standard water ejector or an optional vacuum pump upgrade. Subsequent to the drying phase, the chamber is returned to atmospheric pressure by admitting air through a bacteria-retentive filter.

Steam Source

Sterilizers are piped valved, and trapped to receive building-supplied steam delivered at 50 to 80 psig (344.7 to 551.6 kPa) dynamic. If building steam source is not available, an electric carbon-steel steam generator or electric stainless-steel steam generator may be provided to supply steam to the sterilizer. Steam piping is constructed of brass and includes a shutoff valve, steam strainer and a brass pressure regulator.

Optional stainless-steel indirect-type steam generator can be installed as a pure steam source. Pure steam reduces the probability of contamination which could adversely affect research, such as tissue culture and trace metals studies.

Steam feeds from the jacket to the chamber. A check valve is added between the jacket and chamber on sterilizers with decontamination cycle option.

Piping

All piping connections terminate within the confines of the sterilizer and are accessible from the front and side of sterilizer.

- **Solenoid Valves** in manifold with DIN connectors simplify sterilizer piping and can be serviced individually.
- **Manual Shutoff Valves** are pressure rated at 125 psig (862 kPa) for saturated steam. Valve handles are low-heat conducting.

MOUNTING ARRANGEMENT

Sterilizers are arranged for either freestanding or recessed installation, as specified. Each sterilizer is equipped with a height-adjustable, steel floor stand. Sterilizer subframe is equipped with a synthetic rubber gasket to ensure tight fit between the cabinet panels on freestanding units or between the front cabinet panel and wall partition on recessed units.

On freestanding units, stainless-steel side panels enclose the sterilizer body and piping.

Each AMSCO 110LS and AMSCO 250LS sterilizer has a lockable front service panel.

OPTIONS

Stainless-steel piping to chamber delivers steam generated from Customer purified water source to the chamber and its contents. All steam-to-chamber piping components are constructed of 300 series stainless steel. Option is provided with Pressure Reducing Valve. Compressed air required for pneumatic valves.

Integral indirect stainless-steel clean steam generator automatically produces clean steam using Customer-supplied steam and purified water. Generator is integrally connected to the clean steam-to-chamber piping system.

30 kW carbon-steel electric steam generator typically fed by a potable water source with hardness not to exceed 171 mg/L. The generator is available for both single and double door sterilizers. The generator is mounted underneath both single and double door units. The generator option is not available for AMSCO 110LS double door units.

30 kW electric stainless-steel steam generator is electrically powered, automatically filled with water having 1 M Ω ·cm resistivity, and operates whenever the sterilizer power is on. Generator is integrally connected to the clean steam-to-chamber piping system. The generator option is not available for AMSCO 110LS double door units.

Auto Flush for Steam Generator provides automatic flush of steam generator upon startup of sterilizer. Not required for SS generators.

RTD load probes and F₀ sterilization (maximum of 2) automatically sense the load temperature during cycle operation. A single thermal load probe is sealed through the sterilizer vessel and manually placed in the product container within the chamber prior to cycle operation.

In conjunction with the load probe option, individual cycles can be set to start exposure phase according to chamber drain temperature or according to load temperature. Also, F₀ set points are available for each cycle, allowing for exposure phase termination based on the calculated F₀ value.

Bioseal (for AMSCO 250LS double manual door units only) is a 1/4" steel plate which is welded to the chamber and a 1/4" thick silicone gasket that extends between the plate and a carbon steel wall frame which is welded to wall imbeds. The bioseal is provided on the non-operating end of the sterilizer, prevents passage of airborne microorganisms from the space between the vessel body and the structural wall opening. Steam is the primary source of pressure behind the door seal. All sterilizers with bioseals have air back-up to maintain seal pressure when out of cycle or if the steam source is not available.

Air-differential seal (double door units only), provided on the non-operating end of the sterilizer, minimizes airflow between the dirty and clean sides of the barrier.

Back cabinet panel is provided on single door, freestanding units where the unit is accessible on all sides.

Air detector (integral factory piping option) is used to determine whether any air or non-condensable gas present in the chamber is sufficient to impair the sterilizing process.

Backflow preventer option can be installed on sterilizer piping to prevent the unwanted reverse flow of water or other substances into the potable water supply.

Power door provides automatic opening and closing by depressing a foot pedal. (Not available for sterilizers with Bio-Seal option).

Vacuum Pump Upgrade: Water ejector is replaced with a water ring vacuum pump.

Drain line reference probe automatically senses the drain line temperature during cycle operation. During the Sterilize phase, the chamber and reference probes are compared and if the difference is outside the allowable range, an alarm will occur. This option replaces the standard drain RTD probe with a dual element RTD probe, in the same sheathing.

0.2 micron bacterial retentive filter provides sterile air during airbreak at end of cycle.

Reference recorder: An optional independent recorder is provided to record chamber drainline temperature and chamber pressure. The recorder is remote mounted.

Additional chamber penetration: One 1" NPT capped chamber penetration port is located at the side of the vessel so as not interfere with other piping. The port provides for up to twelve (12) owner provided thermocouple probes or other test instrumentation.

One port is provided as standard on AMSCO 250LS.

Printer on both ends. An additional printer is provided on the non-operating end of the sterilizer.

Dry Contacts provide four (4) relays to communicate the following equipment status: door open, door closed, alarm, and unit on.

ACCESSORIES

Air Compressor, Portable, 115 Vac. This accessory is intended for pneumatic valves on sterilizers when an air utility is not provided by the facility. It may also be used for back-up pressure source for the door seal in bioseal applications.

This is a portable 1.5 Gallon compressor tank that delivers 48 LPM @ 689 KPa (1.7CFM @ 100 PSI). Refer to STERIS drawing no. 755718-038 for complete specifications.

NOTE: UL/CSA certified only.

Seismic tie-down kit conforms to current California Code of Regulations.

PREVENTIVE MAINTENANCE

A global network of skilled service specialists can provide periodic inspections and adjustments to help ensure low-cost, peak performance. STERIS representatives can provide information regarding annual maintenance agreements.

NOTES

1. The sterilizer is not supplied with a vacuum breaker or backflow preventer and, where required by local codes, installation of such a device in water line is not provided by STERIS.
2. Pipe sizes shown indicate terminal outlets only. Building service lines, not provided by STERIS, must supply the specified pressures and flow rates.
3. Disconnect switches (with OFF position lockout only; not provided by STERIS) should be installed in electric supply lines near the equipment.
4. Access to the recessing area from the control end of the sterilizer is recommended.
5. Clearances shown are minimal for installing and servicing the equipment.
6. If loading car and carriage are to be used with a AMSCO 250LS sterilizer, front clearance should equal twice the length of the sterilizer. This will permit complete withdrawal of the loading car from the chamber and allow convenient maneuverability of the transfer assembly to and from the sterilizer.
7. Floor drain should be provided within confines of sterilizer framework.

UTILITY REQUIREMENTS

Refer to Equipment Drawing for complete information.

Sterilizer Using Facility Steam¹

Steam

1/2" NPT, 50 to 80 psig (344.7 to 551.6 kPa) dynamic, 97 to 100% vapor quality

Drain

1-1/2" ODT drain terminal. (Floor drain capacity must handle peak water consumption; refer to engineering data.)

Electrical - Controls

120 Volt, 50/60 Hz, 1-phase, 3.0 Amp

International:

230 Volt, 50/60 Hz, 1-Ph, 1.5 Amp

Sterilizer Feed Water

1.0" NPT, 30 to 50 psig (206.8 to 344.7 kPa) dynamic. Water is used for ejectors, vacuum pumps, exhaust condensers, and trap cooling. Refer to **Table 1** for recommended water quality. Use of feed water within the nominal conditions will optimize equipment performance and reduce maintenance.

NOTE: Backflow prevention is not standard on the unit, but a backflow preventer option can be ordered.

Sterilizer Equipped With Integral Carbon Steel Steam Generator

Drain

1-1/2" ODT drain terminal. (Floor drain capacity must handle peak water consumption; refer to engineering data.)

Generator Drain

1/2" ODT

Electrical - Controls

120 Volt, 50/60 Hz, 1-phase, 9.5 Amp

International:

230 Volt, 50/60 Hz, 1-Ph, 1.5 Amp

Electrical - Generator

208 Volt, 50/60 Hz, 3-phase

240 Volt, 50/60 Hz, 3-phase

480 Volt, 50/60 Hz, 3-phase

600 Volt, 60 Hz, 3-phase

International:

380/415 Volt, 50/60 Hz, 3-Ph, (Prevacuum Units)

Sterilizer Feed Water

1.0" NPT, 30 to 50 psig (206.8 to 344.7 kPa) dynamic. Refer to **Table 1** for water specification guidelines.

Steam Generator Feed Water

1/2" NPT, 20 to 50 psig (137.9 to 344.7 kPa) dynamic. Refer to **Table 2** for required water quality. Use of feed water within the nominal conditions will optimize equipment performance and reduce maintenance.

NOTE: Backflow prevention is not standard on the unit, but a backflow preventer option can be ordered.

Sterilizer Equipped With Integral Stainless-steel Steam Generator

Sterilizer Feed Water

1.0" NPT, 30 to 50 psig (206.8 to 344.7 kPa) dynamic. Refer to **Table 1** for required water quality.

Steam Generator Feed Water

1/2" NPT, 20 to 50 psig (137.9 to 344.7 kPa) Refer to **Table 3** for required water quality.

Drain

1-1/2" ODT generator drain terminal. (Floor drain capacity must handle peak water consumption; refer to engineering data.)

Generator Drain

1/2" ODT

Electrical - Controls

120 Volt, 50/60 Hz, 1-phase, 9.5 Amp

International:

230 Volt, 50/60 Hz, 1-Ph, 1.5 Amp

Electrical - Generator

208 Volt, 50/60 Hz, 3-phase

240 Volt, 50/60 Hz, 3-phase

480 Volt, 50/60 Hz, 3-phase

600 Volt, 60 Hz, 3-phase

International:

380/415 Volt, 50/60 Hz, 3-Ph, (Prevacuum Units)

Refer to the Following Equipment Drawings for Installation Details

Equipment Drawing Number	Equipment Drawing Title
AMSCO 110LS	
387362-169	110LS, SINGLE DOOR, RECESSED, STEAM HEAT
387362-170	110LS, SINGLE DOOR, CABINET, STEAM HEAT
387362-171	110LS, SINGLE DOOR, RECESSED, ELECTRIC STEAM
387362-172	110LS, SINGLE DOOR, CABINET, ELECTRIC STEAM
387362-173	110LS, DOUBLE DOOR, RECESSED 1 WALL, STEAM HEAT
AMSCO 250LS	
387362-159	250LS, SINGLE DOOR, RECESSED, STEAM HEAT
387362-160	250LS, SINGLE DOOR, CABINET, STEAM HEAT
387362-161	250LS, SINGLE DOOR, RECESSED, ELECTRIC STEAM
387362-162	250LS SINGLE DOOR, CABINET, ELECTRIC STEAM
387362-163	250LS, DOUBLE DOOR, RECESSED 1 WALL, STEAM HEAT
387362-164	250LS, DOUBLE DOOR, RECESSED 2 WALLS, STEAM HEAT
387362-165	250LS, DOUBLE DOOR, RECESSED 1 WALL, ELECTRIC STEAM
387362-166	250LS, DOUBLE DOOR, RECESSED 2 WALLS, ELECTRIC STEAM

Table 1. Recommended Feed Water Quality for Sterilizers

Condition	Nominal Conditions	Maximum Conditions
Temperature	40°-60°F (4°-16°C)	70°F (21°C)
Total Hardness as CaCO ₃ *	50-120 mg/L	171 mg/L
Total Dissolved Solids	100-200 mg/L	500 mg/L
Total Alkalinity as CaCO ₃	70-120 mg/L	180 mg/L
pH	6.8-7.5	6.5-8.5
Total Silica	0.1 - 1.0 mg/L	2.5 mg/L

* 17.1 mg/L = 1.0 grain hardness

Table 2. Required Feed Water Quality for Carbon-Steel Steam Generators

Condition	Nominal Conditions	Maximum Conditions
Temperature	70-140°F (21-60°C)	140°F (60°C)
Total Hardness as CaCO ₃ *	0-17 mg/L	130 mg/L
Total Dissolved Solids	50-150 mg/L	250 mg/L
Total Alkalinity as CaCO ₃	50-100 mg/L	180 mg/L
pH	6.8-7.5	6.5-8.5
Total Silica	0.1 - 1.0 mg/L	2.5 mg/L
Resistivity †	2 - 6 kΩ·cm	26 kΩ·cm

* 17.1 mg/L = 1.0 grain hardness

† **WARNING-BURN HAZARD:** Never use supply water with resistivity exceeding 26 kΩ·cm, as doing so may cause malfunction of steam generator level control, resulting in sterilizer operator being severely burned by scalding water. If supply water resistivity exceeds 26 kΩ·cm immediately contact STERIS Service Engineering.

Table 3. Required Feed Water Quality Stainless Steel Generators

Type of Water	Deionized Water, Distilled or Reverse Osmosis
Temperature	70-140°F (21-60°C)
Minimum Specific Resistivity	1.0 MΩ·cm

NOTE: Do not connect tap water to stainless-steel steam generator. Use of water not meeting the required feed water quality will invalidate the warranty and is a violation of ASME Boiler Codes.

ENGINEERING DATA

Model & Chamber Size in (mm)	Heating	MAXIMUM OPERATING WEIGHT ^a lbs (kg)		HEAT LOSS ^b BTU/hr at 70°F (21°C)						
				Single Door			Double Door			
		Single Door	Double Door	Cab't Enc	Recessed		Recessed One Wall		Recessed Two Walls	
				To Room	Front of Wall	Back of Wall	Front of Wall	Back of Wall	At Each End	Between Walls
AMSCO 110LS 16 x 16 x 26 (406 x 406 x 660)	Steam	750 (340)	989 (449)	4300	1600	2700	1600	3500	N/A	N/A
	Electric	890 (404)	N/A	6050	2300	3750	N/A	N/A	N/A	N/A
AMSCO 250LS 20 x 20 x 38 (508 x 508 x 965)	Steam	1231 (558)	1606 (728)	7000	2500	4500	2500	5300	2500	2800
	Electric	1371 (622)	1726 (782)	8750	3300	5450	3300	6250	3300	2950

Model & Chamber Size in (mm)	Heating	UTILITIES CONSUMPTION									
		Water ^c							Steam		
		Cold			Hot ^d						
		Peak gpm (lpm)	Per Cycle ^e gal/cycle (l/cycle)	Idle gph (lph)	Peak gpm (lpm)	Per Cycle ^e gal/cycle (l/cycle)	Idle gph (lph)	Peak ^f lb/hr (kg/hr)	Per Cycle ^e lb/cycle (kg/cycle)	Idle lb/hr (kg/h)	
AMSCO 110LS 16 x 16 x 26 (406 x 406 x 660)	Steam	6 (23)	68 (257)	7 (27)	N/A	N/A	N/A	180 (81)	18 (8)	7 (3)	
	Electric	6 (23)	68 (257)	7 (27)	1 (4)	3 (11)	1 (4)	N/A	N/A	N/A	
AMSCO 250LS 20 x 20 x 38 (508 x 508 x 965)	Steam	6 (23)	70 (265)	10 (38)	N/A	N/A	N/A	180 (81)	21 (10)	7 (3)	
	Electric	6 (23)	70 (265)	10 (38)	1 (4)	4 (15)	1 (4)	N/A	N/A	N/A	

^a Based on chamber fully loaded with water flasks.

Noise level is based on the vacuum pump, 74 dB at 24"Hg vacuum.

Estimated noise level of 68dB for units with water ejector.

^b At 70°F (21°C).

^c Backflow preventer device in water line, when required by local codes, is not provided by STERIS.

^d Hot water recommended for units equipped with electric steam heat.

^e Based on Prevac cycle, 3 pulses, 30 minute exposure time and 5 minute dry time. Tested with empty chamber.

^f Peak steam demand (lbs/hr) may vary depending on operating conditions.

Additional utilities are required for units with the following options:

- Liquid Air Cool (Compressed Air)
- Decontamination Cycle (Compressed Air)
- Bio-Seal and Air Differential Seal (Optional Compressed Air Backup)
- Vacuum Pump (3-Phase Voltage)
- Stainless-Steel Piped Units (Treated Water)
- Steam Source (one of the following):
 - >> Integral Steam Generator - Carbon Steel or Stainless Steel (3 Phase Voltage)
 - >> Indirect Steam Generator; Minimum 75 psig Steam Required

Consult Customer service for specially configured equipment drawings.

**CUSTOMER IS RESPONSIBLE FOR COMPLIANCE WITH
APPLICABLE LOCAL AND NATIONAL CODES AND
REGULATIONS.**

**The base language of this document is ENGLISH.
Any translations must be made from the base language
document.**

For further information, contact:



STERIS Corporation
5960 Heisley Road
Mentor, OH 44060-1834 • USA
440-354-2600 • 800-548-4873
www.STERISLifeSciences.com



Each pressure vessel is individually inspected and hydro pressure tested.



RELIABILITY

Reliability is a key requirement for any busy laboratory research facility. With STERIS, reliability starts in our ISO 9001 certified factory with a rigorous final inspection at our state-of-the-art testing facility.

- From the durable AMSE/PED certified stainless steel chamber and jacket, to the easily accessible parts, the AMSCO LS Series Small Laboratory Steam Sterilizer is designed to minimize downtime
- Our unique door seal that never needs lubrication is protected by a two-year warranty
- One-year warranty backed up by a global network of 1000 factory trained service technicians



AMSCO® LS Series Small Laboratory Steam Sterilizer



STERIS CORPORATION
5960 Heisley Road
Mentor, OH 44060, USA
T +1 800 444 9009

www.STERISLifeSciences.com

STERIS Offices Worldwide

Asia Pacific	+65 (0) 68 41 7677
Canada	+1 800 444 9009
Finland	+358 9 25851
France	+33 (0) 2 38 84 85 40
Germany	+49 (0) 221 466120
Italy	+39 (0) 2 21303 424
Latin America	+1 800 444 9009
Spain	+34 (0) 916 585 920
United Kingdom	+44 (0) 1256 840400

STERIS Life Sciences | Science & Solutions for Life

For over 100 years, STERIS has been known as a global leader, trusted partner and solutions provider in the field of sterilization and contamination control. *Today*, STERIS continues building on this heritage by advancing the **Science** of sterilization, cleaning and infection control while offering **Solutions** that meet our Customers' needs and high standards. STERIS is dedicated to helping you enhance the **Life** of your patients and the life of your equipment. From Formulated Chemistries, to Capital Equipment, to Parts and Services, STERIS Life Sciences is **Science & Solutions for Life**.

© 2015 STERIS Corporation
All rights reserved

No part of this publication may be reproduced in any material form without the permission of STERIS Corp.

The AMSCO LS Series Small Laboratory Steam Sterilizer is designed for fast and efficient sterilization of heat- and moisture- stable materials used in scientific applications. Incorporating safety and reliability, the easy-to-use AMSCO LS Series Small Laboratory Steam Sterilizer is also flexible and sustainable.

The AMSCO LS Series Small Laboratory Steam Sterilizer comes in two chamber sizes: **AMSCO 110LS** 16 x 16 x 26" (406 x 406 x 660mm)
AMSCO 250LS 20 x 20 x 38" (508 x 508 x 965mm)

- Allen Bradley Control provides up to 20 programmable cycles along with standard Daily Air Removal Test and Leak Test
- Impact Printer is provided to maintain records
- Option integrated vacuum pump and electric steam generator are available
- Loading accessories are available as either an internal rack and two shelves or loading car and transfer carriage



SUSTAINABILITY

The AMSCO LS Series Small Laboratory Steam Sterilizer is equipped with many standard features designed to easily conserve the use of water and energy, including auto utility start up and shut-down, a stand by mode that shuts down the jacket and generator and a new green mode that only turns off the jacket thereby conserving energy, but can quickly return to temperature to begin a cycle.

The AMSCO LS Series Small Laboratory Steam Sterilizer can also be equipped with the STERI-Green® and STERI-Green Plus® Water Conservation systems. These systems can fit within the footprint of the sterilizer with the vacuum pump to conserve space as well.



The STERI-Green Water Conservation system can reduce water consumption by 45 to 55% per sterilization cycle.



The STERI-Green Plus Water Conservation system can reduce water consumption up to 99% - virtually eliminating the need for any domestic water required for cooling.



CONNECTIVITY

The AMSCO LS Series Small Laboratory Steam Sterilizer autoclaves include many advanced control features to provide text or email alerts. All printer data is saved internally and can be viewed on the control panel and emailed as a pdf. The control is also able to be connected to a building management system for remote monitoring. Optional dry contacts are available to connect to a Building Management System.



VERSATILE AND FLEXIBLE

The AMSCO LS Series Small Laboratory Steam Sterilizer is suited for basic lab applications, but is equipped with options for more demanding cycles as well. Each sterilizer comes programmed with the standard pre-vac, liquid and gravity cycles. However, each unit is also programmed with a waste bag cycle preconfigured to assist with the removal of air trapped inside the bag. The cycle has shown to reduce the cycle time required for lab waste bags significantly. Each control is also pre-programmed with a cycle designed to meet the USP 660 standard for sterilizing glassware.

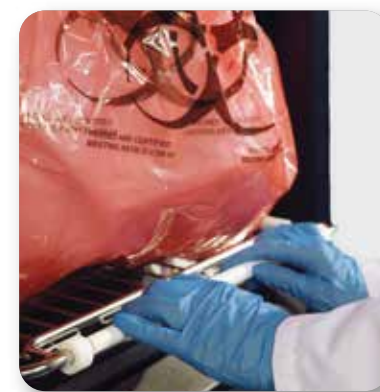

HIGH CONTAINMENT

The AMSCO 250LS can be provided with an air differential seal or a bioseal. Effluent decontamination cycle utilizing a 0.2 micro filter is available.

APPLICATION

AMSCO 110LS and AMSCO 250LS Small Sterilizers are designed for use in laboratory and industrial applications. Each is configured with pre-vacuum, liquid, and gravity cycles. A full list of standard and optional cycles begins on page 2.

DESCRIPTION

AMSCO 110LS and AMSCO 250LS Small Sterilizers for life science applications are the next advancement in the STERIS line of steam-jacketed sterilizers. Both sterilizers are equipped with the latest features in state of the art technology and ease of use.

Interior Chamber Dimensions

- **AMSCO 110LS** – 16 x 16 x 26" (406 x 406 x 660 mm), 110L capacity
- **AMSCO 250LS** – 20 x 20 x 38" (508 x 508 x 965 mm), 250L capacity

Allen-Bradley MicroLogix™ Control System with enhanced functionality and user-friendly Allen-Bradley PanelView Plus™ 7 700 interface screen.*

- Touch-sensitive screen with 18-bit color graphic display
- Display features 640 x 480 resolution color-active matrix



(Typical - details may vary.)

Selections Checked Below Apply To This Equipment

MODEL/CHAMBER SIZE (W x H x L)

- AMSCO 110LS**
16 x 16 x 26" (406 x 406 x 660 mm)
 Prevacuum (LV-110) Isothermal (LI-110)
- AMSCO 250LS**
20 x 20 x 38" (508 x 508 x 965 mm)
 Prevacuum (LV-250) Isothermal (LI-250)

STEAM SOURCE

- Building Steam
- Stand Alone Electric Steam Generator
 STERIS Provided Customer Provided
- Integral Electric Steam Generator¹
 Carbon Steel Stainless Steel
Voltage Options
 - 208 Volt, 60 Hz
 - 240 Volt, 60 Hz
 - 400 Volt, 50 Hz
 - 480 Volt, 60 Hz
 - 600 Volt, 60 Hz
- Integral Indirect Stainless-Steel Clean Steam Generator (SD589)¹⁰

SINGLE DOOR

- Cabinet Enclosed/Freestanding
- Recessed

DOUBLE DOOR

- Recessed through One Wall
- Sterile side Non-sterile side
- Recessed through Two Walls²

OPTIONS

- Power Door(s)
- Liquid Air Cool (w/vacuum)

- Effluent Decontamination Cycle
- Pure Steam Piping to Chamber
- Air Detector System
- Reference Recorder
- Printer on Both Ends⁸
- Bioseal³
- RTD Load Probe(s) and F₀ Sterilization
 One Probe Two Probes (max. 2)
- Drain Line Reference Probe
- Air-Differential Seal (NOE) for Double Door Units
- Back Panel for Single Door Cabinet Enclosed Unit
- 1" Chamber Penetration, Qty. 1 (AMSCO 110LS only)⁴
- One Additional Chamber Penetration (AMSCO 250LS)⁴
- Vacuum Pump⁵
 - 120 V, 1-Ph / 208 / 240 Vac, 3-Ph
 - 120 V, 1 Ph / 240 Vac 3-Ph
 - 120 V, 1-Ph / 480 Vac, 3-Ph
 - 120 V, 1-Ph / 600 Vac, 3-Ph
 - 230 V, 1 Ph / 400 Vac, 3-Ph (International)
 - Other - Specify _____
- Dry Contacts
- Backflow Preventer
- Auto Flush for Steam Generator
- 0.2 Micron Bacterial Retentive Filter
- Green Gravity Water Saver System
- STERI-GREEN® Water Conservation System
- STERI-GREEN PLUS® Water Conservation System (Chilled water required)

ACCESSORIES (for AMSCO 110LS)⁶

- One Intermediate Shelf (16 x 16 x 26")
- Air Compressor, Portable, 115 Vac

ACCESSORIES (for AMSCO 250LS)

- One Intermediate Shelf (20 x 20 x 38")
- Seismic Tie-Down Kit^{7,9}
- Air Compressor, Portable, 115 Vac
- Loading Rack and Two Shelves (20 x 20 x 38")
 - Single Door Double Door
- Loading Car
- Transfer Carriage
- Chamber Track Assembly
 - Single Door Double Door
- Loading Car, Transfer Carriage & Chamber Track Assembly
 - Single Door Double Door

Notes:

- AMSCO 110LS double door sterilizers are not available with integral electric steam generator.
- Available for AMSCO 250LS double door sterilizers only. Contact engineering if mounting through two walls is required for AMSCO 110LS.
- Available on AMSCO 250LS double manual door sterilizers only.
- One chamber penetration is standard on AMSCO 250LS.
- 1-Ph is for control, 3-Ph is for pump motor
- Loading rack & 2 shelves standard on AMSCO 110LS.
- Based on CA requirements.
- Printer at operating end is standard. Option adds additional printer to non-operating end.
- Units with Bioseal require special seismic kit.
- Integral indirect clean steam generator requires field certification for UL/CSA.

Item _____

Location(s) _____

* Allen-Bradley MicroLogix™ and Allen-Bradley PanelView Plus™ are registered trademarks of Rockwell Automation, Inc.

- Display is designed with emphasis on human factors and user recognizable symbols.
- Noise level for units with water ejector 68DbA, units with vacuum pump 74DbA.

Cycle Programming and Flash Memory

- **20 cycles** may be individually selected and programmed
- Help screens for control operation
- Program permanently stored in flash memory
- Variables permanently stored in flash memory

Vertical Sliding Door(s)

AMSCO LS configurations include choice of single or double door sterilizers and open or recessed mounting. The doors are manually operated. Door seals (1 per door) are non-lubricated, steam activated.

NOTE: Recess two wall mounting is not available for AMSCO 110LS double door sterilizers.

Modularized Vessel And Piping

Vessel and piping are designed for increased dependability and reduced service time.

- Reduced piping components increase reliability
- Vessel design allows higher operating temperature of 141°C (285°F)
- Non-clogging chamber drain line prevents media from plugging drain line
- Emergency manual exhaust valve

STANDARDS

Each sterilizer meets applicable requirements of the following listings and standards, and carries the appropriate symbols.

• Governing Directives for Affixing the CE Mark:

- » Low-Voltage Directive (2014/35/EU)
- » EMC Directive (2014/30/EU)
- » Machinery Directive (2006/42/EEC)

• Pressure Equipment Directive (PED): 97/23/EC.

• **UL/EN/CSA 61010-1:** Safety Requirements for Electrical Equipment for Measurement, Control, and Laboratory Use Part 1: General Requirements

• **UL/EN/CSA 61010-2-040:** Safety Requirements For Electrical Equipment For Measurement, Control, And Laboratory Use, Part 2-040: Particular Requirements For Sterilizers And Washer-Disinfectors Used To Treat Medical Materials

• **ASME Code, Section VIII, Division 1** for unfired pressure vessels. The pressure vessel is so stamped; ASME Form U-1 is furnished. The shell and door are constructed to withstand a working pressure of 45 psig (3.1 bar).

CYCLE DESCRIPTIONS

Standard and optional cycles are as follows:

Gravity Cycle (standard) provided on prevacuum, and isothermal sterilizers, for sterilization of heat- and moisture-stable goods at 100°C to 141°C (212°F to 285°F), and decontamination of bagged non bio-hazardous laboratory wastes. Gravity cycle utilizes gravity air-displacement principle. However, the gravity cycle has a standard drying phase which uses a vacuum. The drying phase can be disabled.

Liquid Cycle (standard) provided on prevacuum, and isothermal sterilizers, for sterilization of liquids and media in vented borosilicate glass or metal containers at 100°C to 141°C (212°F to 285°F). Liquid cycle uses optimal solution cooling feature, during exhaust (cooling) phase, to control exhaust rate.

Prevacuum Cycle (standard) provided only on prevacuum sterilizer, for efficient, high-volume sterilization of porous, heat- and moisture-stable materials at 100°C to 141°C (212°F to 285°F). Prevacuum cycle utilizes a mechanical air-evacuation system.

USP 660 Cycle (standard) developed to assist meeting the requirements of USP 660 sterilization test cycle for glassware. Load probe option is recommended when using this USP cycle.

Continuous Cycle (standard) This cycle allows for up to 9,999 cycles to be run consecutively without the need of an operator. Cycle parameters can be set, along with the amount of time to lapse in between cycles. For this cycle to function, a power door is required to facilitate automatic opening and closing.

Waste Bag Cycle (standard) This cycle has been preconfigured with cycle parameters shown to be effective when processing lab waste in autoclavable bags. Through air removal assistance and a controlled exhaust, the internal temperature is increased more effectively and faster, while minimizing boil over of any liquids present. Parameters may need to be adjusted based on specific loads. Bags should not be completely sealed.

Isothermal Cycle (optional) provided only on isothermal sterilizer, for processing of heat-sensitive and heat-coagulable solutions in vented borosilicate glass or metal containers at 78°C to 110°C (170°F to 230°F). Isothermal cycle utilizes steam to enhance temperature control and prevent layering of steam and air within the chamber. Process maintains positive pressure in chamber to inhibit media boiling.

NOTE: Temperature control spread is greater on Isothermal units $\pm 6^{\circ}\text{C}$.

Liquid Air Cool (Optional) provides water to jacket, and air pressure to chamber to improve exhaust time for liquid loads, and to reduce boil-over.

ATF 1 and ATF 2 Cycles (Alternating Tangential Flow) are designed to sterilize the XCell™ ATF system. These can be used for other purposes that require rates and hold times in the pre-conditioning pulses and a cool down in exhaust by temperature.

Effluent Decontamination Cycle (Optional) is used for processing contaminated laboratory waste (BL-3 and BL-4). Condensate produced during processing cycle is decontaminated before discharge to floor drain. Steam is admitted through bottom of sterilizer chamber, and chamber is exhausted out top side of vessel. During purge and vacuum pulses, all purge and exhaust gases are vented through a 0.2 micron bacterial retentive filter. Filter housing is steam jacketed to prevent wetting of filter membrane. Available with fast exhaust or optimal solution cooling (slow exhaust) exhaust types. User is responsible for development of process parameters.

Leak Test Cycle, for verification of door seal and piping system integrity. Cycle parameters are pre-programmed and fixed. Acceptable maximum leak rate is 1.0 mm Hg/minute over a 10-minute period following a fixed stabilization time.

Daily Air Removal Test (Dart) Cycle, provided only on prevacuam sterilizer, for verification of effective removal of residual air in chamber and load during testing. Test cycle determines if even and rapid steam penetration into test load occurred. Cycle parameters are preprogrammed and fixed.

Bowie-Dick Test is available for 121°C (250°F) and 132°C (270°F) prevacuam cycles.

Healthcare Cycles - The LS Series sterilizers can be programmed to reproduce cycles that are used for healthcare applications, however, these sterilizers do not have FDA clearance and cannot be used for patient treatment applications

ENVIRONMENTAL SUSTAINABILITY

Automatic Utilities Startup/Shutdown

This feature permits slow cooling of the entire vessel and load. Shutdown may be programmed to activate at the end of any designated cycle or time of day. When activated, control system automatically shuts off all utility valves, conserving steam and water usage. Sterilizer utilities can be restarted either by programmed time or manual operation. A different shutdown and restart time can be programmed for each day.

Green Mode

The Green Mode is a standard feature on the control that will shut off the steam to the jacket after the unit has sat idle for a specified period of time. The specific time frame is determined by the user and entered into the control during set up; it can be changed at any time.

Green Gravity Water Saver System

The Green Gravity Water Saver System provides additional water savings by collecting steam effluent and holding it in a cooling tank, reducing the amount of water required to cool the effluent.

STERI-GREEN® Water Conservation System

This system significantly reduces the consumption of potable water. The STERI-GREEN system utilizes a mixing tank and an air-cooled heat exchanger to cool and recycle vacuum pump water and steam effluent. Water temperature is constantly monitored to minimize the need to add fresh cool water to the mixing tank. The system can provide up to 79% water savings over the vacuum pump alone, or up to 87% over a water ejector. When ordered, system includes a vacuum pump (3-phase power required).

STERI-GREEN PLUS® Water Conservation System

The STERI-GREEN PLUS system utilizes facility chilled water supply. The system utilizes a mixing tank and a series of heat exchangers, integrated with the a chilled water loop, to cool and recycle vacuum pump water and effluent. Water temperature is constantly monitored to minimize the need to add fresh cool water to the mixing tank. This system provides up to 99% water savings over water ejector or vacuum pump upgrade alone. When ordered, system includes a vacuum pump (3-phase power required).

STANDARD FEATURES

Hinged front cabinet panel opens for convenient access to sterilizer piping and control system.

Resistance Temperature Detectors (RTDs) are installed for sterilizer temperature control. The chamber drain line RTD senses and controls temperature variations within the sterilizer chamber. A jacket RTD provides temperature control within the jacket space. These RTD signals, converted into electrical impulses, provide accurate control inputs and readouts throughout entire cycle.

Software calibration is provided for all temperature and pressure inputs. Calibration is performed in the service mode, accessible through the touch screen displays, and accomplished using external or internal temperature and pressure sources. Control system provides a printed record of all calibration data for verification to current readings.

Cycle Data Records, recorded on the printer tape. They can also be retrieved for on-screen review, USB, or sent via e-mail if the system is enabled. The e-mail feature requires a network connection.

Optimal solution cooling is designed to safely cool various liquids in vented, borosilicate glass containers with minimum liquid loss due to boil-over, and to keep normal evaporation loss below 5%. Optimal solution cooling is an integral part of the factory-programmed liquid cycle. During the exhaust (cooling) phase, the control utilizes this feature to optimize the exhaust rate regardless of load size or container fill volume, up to one liter. During cooling, the initial rate, initial rate transition point, as well as the second rate and final vacuum level are adjustable.

Steam purge feature is provided to assist in air removal and preheat the load.

Automatic steam shutoff to jacket is provided for isothermal and liquid cycles. When activated for isothermal cycles, the jacket control conducts a timed jacket drain, automatically allowing for the operation of cycles at lower temperatures. When activated for liquid cycles, steam supply to the jacket is turned off during exhaust phase, allowing load to cool more efficiently.

Insulation, one-inch thick, asbestos-free spin-glass (rated at 1000 °F [538 °C] continuous) encompasses the exterior of the sterilizer vessel and is sealed in an oil and water resistant outer jacket.

Lighted DIN connectors are installed on all steam, water, and exhaust valves for reliability and ease of maintenance.

Air Backup to seals is provided on all double door sterilizers, with either bioseal or air differential seals.

Visible Gauges are standard. Chamber and jacket pressure gauges are standard on the operating end and non-operating end.

CONTROL SYSTEM

Design Features

Together, the Allen-Bradley MicroLogix™ PLC control and PanelView Plus™ 7 700 display, monitor and control all sterilizer operations and functions. Control system is factory-programmed with standard sterilizing cycles, each adjustable to meet specific processing requirements. All control configuring is performed through touch screen displays.

Cycle values and operating features may be adjusted and verified prior to cycle operation. Once cycle is started, cycles and cycle values cannot be changed until cycle is complete. On completion of cycle, timers reset to the previously selected values, eliminating the need to reset values between repeated

cycles. If chamber temperature drops below the under temperature setting during the exposure phase, timer can be set to stop and automatically reset or resume once normal operating temperature is reached.

Critical control system components are housed within a sealed compartment to protect components from moisture and heat generated during sterilization process.

The control system is provided with features such as audit trail, password management and electronic signatures, which can



Typical Cycle Menu Display

facilitate compliance to 21 CFR Part 11 (Code of Federal Regulations Title 21)

Operator interface control panel, consisting of touch screen and thermal printer, is located on operating (load or nonsterile) end of sterilizer. If the sterilizer is equipped with double doors, an additional touch screen is provided on the non-operating (unload or sterile) end.

- **Touch-Sensitive Screen** features a color active matrix 18-bit graphics display. All sterilizer functions, including cycle initiation and cycle configuration, are operated by pressing the touch-sensitive areas on the display, referred to as buttons. Display indicates appropriate control buttons, operator prompts and status messages necessary to assist in sterilizer operation. All displayed messages are complete phrases with no codes to be cross-referenced. Display also indicates any abnormal conditions that may exist either in or out of a cycle.
- **Thermal printer** is a high resolution (8 dots per mm) printer. It is fast and quiet, printing at 25 lines per minute on industrial grade thermal paper. The device provides an easy-to-read printed record of all pertinent cycle data on 2.25" (57 mm) wide paper. Data is automatically printed at the beginning and end of each cycle and at transition points during the cycle. Three paper tape rolls are furnished with each unit. Printouts have a guaranteed lifetime of 25 years and are resistant from exposure to steam, alcohol, UV and visible light, oil, heat and water.
- **Non-operating end (NOE) control panel** (equipped on double-door sterilizers only) includes a touch-sensitive screen similar to the operating end screen. Preprogrammed cycles can be started from the NOE control panel. Display concurrently shows the same information as the operating end screen display.
- **Cycle configuration** is performed by accessing the **change values** menu on either end of a double door sterilizer. Utility shutdown parameters can only be changed on the OE

display. In addition to adjustment of cycle values, the following operating parameters can also be changed through the change values menu:

- » **Time Display and Printout Units** in standard AM/PM or 24-hour military (MIL) time.
- » **Selectable Cycle Name** permits user to name each cycle with any combination of letters, numbers, blank spaces, and underscores, up to eight characters long.
- » **Print Interval** permits adjustment of the time period between cycle-status printouts generated during the sterilize phase.
- » **Security access code** is required to enter the operating mode (running cycles), supervisor mode (changing values), and service mode. Operating the sterilizer or accessing change values menu causes display to request the entry of an access code. If access code is not properly entered, display returns to the standby screen, denying user access to the sterilizer or programming. Access to the sterilizer can be limited to 12 operators, each with a different access code.
- » **Alarm tones** – The end of cycle and alarm tones have adjustable volumes ranging from off, low, medium and high. The alarm tone does not have the selection for off. Touching the display buttons will create audible beep.
- » **Temperature Display and Printout Units** in Celsius (°C) or Fahrenheit (°F). Temperature is set, displayed, controlled, and printed to the nearest 0.1°. Recalibration is not required when changing temperature units from °C to °F and vice versa.
- » **Pressure/Vacuum Display and Printout Units** in psi/In/Hg, Bar (Gauge and Absolute). Recalibration is not required when changing pressure units.

Mobile and PC Messaging (Standard)

This is a standard feature on the control that allows the user to receive text messages or emails alerts regarding the status of the autoclave. The operator can choose from a list of # possible alerts from which to be notified.

SCADA Ready Control Interface (Standard)

If requested, STERIS can provide the user the information to allow communication between the autoclave and the Building Management System. An ethernet connection is required.

Printer Data Storage (Standard)

All printer data is saved internally and can be retrieved and viewed on the display screen, exported to a USB drive or emailed to the User.

Cycle usage (Standard)

Utilization of the sterilizer can be monitored for each User, data can be exported via an Ethernet or USB port.

SAFETY FEATURES

Control lockout switch (equipped on chamber door) senses when door seal is energized and tight against the door. Control prevents cycle from starting until the limit switch signal is received. If control loses appropriate signal during cycle, alarm activates, cycle aborts, and chamber safely vents with a controlled exhaust.

Chamber float switch activates alarm, aborts cycle, and safely vents chamber with a controlled exhaust if excessive condensate is detected in the vessel chamber.

Door interlocks (double door units only) allow only one door to be opened at a time and, during processing, prevent the non-operating end (NOE) door from being opened until a satisfactory cycle is complete. If a cycle is aborted, the NOE door cannot be opened. The use of this feature may affect the door gaskets life expectancy unless an air differential or bio seal is provided.

Pressure relief valve limits the amount of pressure buildup so that the rated pressure in the vessel is not exceeded.

Emergency stop button (located on front of the sterilizer) is included on all sterilizers. A key is required to release the emergency stop (once pushed) before the unit can return to normal operation.

CONSTRUCTION

Shell Assembly

Two fabricated Type 316L stainless-steel shells, welded one within the other, form the sterilizer vessel. Type 316L stainless-steel end frame(s) is welded to door end. On single door units, back of chamber is fitted with welded, 316L stainless-steel formed head.

Sterilizer vessel is ASME rated at 50 psig (3.2 Bar) and insulated. The Vessel (for AMSCO 250LS only) includes one 1.0" (25 mm) NPT welded chamber bushing for Customer use.

Steam-supply opening inside the chamber is shielded by a Type 316L stainless-steel baffle.

Chamber Door(s)

Door is constructed of a single formed piece of Type 316L stainless steel. Door is insulated to reduce the surface temperature of the stainless-steel door cover.

During cycle operation, door is sealed by a **steam-activated door seal**. Door seal is constructed of a special long-life rubber compound. When sterilizer cycle is complete, the seal retracts under vacuum into a machined groove in sterilizer end frame. Door seal can be manually retracted to open the door and remove critical load in an emergency situation (if loss of vacuum or loss of power occurs).

A handle is used to manually open (by lowering) and manually close (by raising) the door which is suspended by cables attached to a counterweight.

A long-life proximity switch is used, by the control, to determine if the door is closed. An additional seal pressure switch prevents inadvertent cycle initiation if door is not sealed.

The door assembly is equipped with a mechanical locking mechanism that ensures the door cannot be opened, as long as the seal is intact and energized, and more than 2.0 psi pressure is in the chamber. Door interlocks on double door sterilizers can be programmed to prevent inadvertent opening of door(s). Access code is required to override door interlocks.

NOTE: Bio-Seal option is available for AMSCO 250LS, double manual door sterilizers, as discussed on page 5.

Chamber Drain System

Drain system is designed to prevent pollutants from entering

into the water-supply system and sterilizer. An optional backflow preventer is available. Water supply shutoff valve is located behind the front cabinet service panel under the chamber.

Automatic Drain Effluent Cooling

The piping system to the drain provides automatic condensing of chamber steam and disposal of condensate to waste.

Cooling water is added to ensure discharge temperature is discharged at or below 60°C (140°F). A separate resistance temperature detector (RTD) is included to limit the volume of water to only the amount required to achieve target temperature, thus conserving water.

Vacuum System

Chamber pressure is reduced during the conditioning phase and drying phase through the means of either a standard water ejector or an optional vacuum pump upgrade. Subsequent to the drying phase, the chamber is returned to atmospheric pressure by admitting air through a bacteria-retentive filter.

Steam Source

Sterilizers are piped valved, and trapped to receive building-supplied steam delivered at 50 to 80 psig (344.7 to 551.6 kPa) dynamic. If building steam source is not available, an electric carbon-steel steam generator or electric stainless-steel steam generator may be provided to supply steam to the sterilizer. Steam piping is constructed of brass and includes a shutoff valve, steam strainer and a brass pressure regulator.

Optional stainless-steel indirect-type steam generator can be installed as a pure steam source. Pure steam reduces the probability of contamination which could adversely affect research, such as tissue culture and trace metals studies.

Steam feeds from the jacket to the chamber. A check valve is added between the jacket and chamber on sterilizers with decontamination cycle option.

Piping

All piping connections terminate within the confines of the sterilizer and are accessible from the front and side of sterilizer.

- **Solenoid Valves** in manifold with DIN connectors simplify sterilizer piping and can be serviced individually.
- **Manual Shutoff Valves** are pressure rated at 125 psig (862 kPa) for saturated steam. Valve handles are low-heat conducting.

MOUNTING ARRANGEMENT

Sterilizers are arranged for either freestanding or recessed installation, as specified. Each sterilizer is equipped with a height-adjustable, steel floor stand. Sterilizer subframe is equipped with a synthetic rubber gasket to ensure tight fit between the cabinet panels on freestanding units or between the front cabinet panel and wall partition on recessed units.

On freestanding units, stainless-steel side panels enclose the sterilizer body and piping.

Each AMSCO 110LS and AMSCO 250LS sterilizer has a lockable front service panel.

OPTIONS

Stainless-steel piping to chamber delivers steam generated from Customer purified water source to the chamber and its contents. All steam-to-chamber piping components are constructed of 300 series stainless steel. Option is provided with Pressure Reducing Valve. Compressed air required for pneumatic valves.

Integral indirect stainless-steel clean steam generator automatically produces clean steam using Customer-supplied steam and purified water. Generator is integrally connected to the clean steam-to-chamber piping system.

30 kW carbon-steel electric steam generator typically fed by a potable water source with hardness not to exceed 171 mg/L. The generator is available for both single and double door sterilizers. The generator is mounted underneath both single and double door units. The generator option is not available for AMSCO 110LS double door units.

30 kW electric stainless-steel steam generator is electrically powered, automatically filled with water having 1 M Ω ·cm resistivity, and operates whenever the sterilizer power is on. Generator is integrally connected to the clean steam-to-chamber piping system. The generator option is not available for AMSCO 110LS double door units.

Auto Flush for Steam Generator provides automatic flush of steam generator upon startup of sterilizer. Not required for SS generators.

RTD load probes and F₀ sterilization (maximum of 2) automatically sense the load temperature during cycle operation. A single thermal load probe is sealed through the sterilizer vessel and manually placed in the product container within the chamber prior to cycle operation.

In conjunction with the load probe option, individual cycles can be set to start exposure phase according to chamber drain temperature or according to load temperature. Also, F₀ set points are available for each cycle, allowing for exposure phase termination based on the calculated F₀ value.

Bioseal (for AMSCO 250LS double manual door units only) is a 1/4" steel plate which is welded to the chamber and a 1/4" thick silicone gasket that extends between the plate and a carbon steel wall frame which is welded to wall imbeds. The bioseal is provided on the non-operating end of the sterilizer, prevents passage of airborne microorganisms from the space between the vessel body and the structural wall opening. Steam is the primary source of pressure behind the door seal. All sterilizers with bioseals have air back-up to maintain seal pressure when out of cycle or if the steam source is not available.

Air-differential seal (double door units only), provided on the non-operating end of the sterilizer, minimizes airflow between the dirty and clean sides of the barrier.

Back cabinet panel is provided on single door, freestanding units where the unit is accessible on all sides.

Air detector (integral factory piping option) is used to determine whether any air or non-condensable gas present in the chamber is sufficient to impair the sterilizing process.

Backflow preventer option can be installed on sterilizer piping to prevent the unwanted reverse flow of water or other substances into the potable water supply.

Power door provides automatic opening and closing by depressing a foot pedal. (Not available for sterilizers with Bio-Seal option).

Vacuum Pump Upgrade: Water ejector is replaced with a water ring vacuum pump.

Drain line reference probe automatically senses the drain line temperature during cycle operation. During the Sterilize phase, the chamber and reference probes are compared and if the difference is outside the allowable range, an alarm will occur. This option replaces the standard drain RTD probe with a dual element RTD probe, in the same sheathing.

0.2 micron bacterial retentive filter provides sterile air during airbreak at end of cycle.

Reference recorder: An optional independent recorder is provided to record chamber drainline temperature and chamber pressure. The recorder is remote mounted.

Additional chamber penetration: One 1" NPT capped chamber penetration port is located at the side of the vessel so as not interfere with other piping. The port provides for up to twelve (12) owner provided thermocouple probes or other test instrumentation.

One port is provided as standard on AMSCO 250LS.

Printer on both ends. An additional printer is provided on the non-operating end of the sterilizer.

Dry Contacts provide four (4) relays to communicate the following equipment status: door open, door closed, alarm, and unit on.

ACCESSORIES

Air Compressor, Portable, 115 Vac. This accessory is intended for pneumatic valves on sterilizers when an air utility is not provided by the facility. It may also be used for back-up pressure source for the door seal in bioseal applications.

This is a portable 1.5 Gallon compressor tank that delivers 48 LPM @ 689 KPa (1.7CFM @ 100 PSI). Refer to STERIS drawing no. 755718-038 for complete specifications.

NOTE: UL/CSA certified only.

Seismic tie-down kit conforms to current California Code of Regulations.

PREVENTIVE MAINTENANCE

A global network of skilled service specialists can provide periodic inspections and adjustments to help ensure low-cost, peak performance. STERIS representatives can provide information regarding annual maintenance agreements.

NOTES

1. The sterilizer is not supplied with a vacuum breaker or backflow preventer and, where required by local codes, installation of such a device in water line is not provided by STERIS.
2. Pipe sizes shown indicate terminal outlets only. Building service lines, not provided by STERIS, must supply the specified pressures and flow rates.
3. Disconnect switches (with OFF position lockout only; not provided by STERIS) should be installed in electric supply lines near the equipment.
4. Access to the recessing area from the control end of the sterilizer is recommended.
5. Clearances shown are minimal for installing and servicing the equipment.
6. If loading car and carriage are to be used with a AMSCO 250LS sterilizer, front clearance should equal twice the length of the sterilizer. This will permit complete withdrawal of the loading car from the chamber and allow convenient maneuverability of the transfer assembly to and from the sterilizer.
7. Floor drain should be provided within confines of sterilizer framework.

UTILITY REQUIREMENTS

Refer to Equipment Drawing for complete information.

Sterilizer Using Facility Steam¹

Steam

1/2" NPT, 50 to 80 psig (344.7 to 551.6 kPa) dynamic, 97 to 100% vapor quality

Drain

1-1/2" ODT drain terminal. (Floor drain capacity must handle peak water consumption; refer to engineering data.)

Electrical - Controls

120 Volt, 50/60 Hz, 1-phase, 3.0 Amp

International:

230 Volt, 50/60 Hz, 1-Ph, 1.5 Amp

Sterilizer Feed Water

1.0" NPT, 30 to 50 psig (206.8 to 344.7 kPa) dynamic. Water is used for ejectors, vacuum pumps, exhaust condensers, and trap cooling. Refer to **Table 1** for recommended water quality. Use of feed water within the nominal conditions will optimize equipment performance and reduce maintenance.

NOTE: Backflow prevention is not standard on the unit, but a backflow preventer option can be ordered.

Sterilizer Equipped With Integral Carbon Steel Steam Generator

Drain

1-1/2" ODT drain terminal. (Floor drain capacity must handle peak water consumption; refer to engineering data.)

Generator Drain

1/2" ODT

Electrical - Controls

120 Volt, 50/60 Hz, 1-phase, 9.5 Amp

International:

230 Volt, 50/60 Hz, 1-Ph, 1.5 Amp

Electrical - Generator

208 Volt, 50/60 Hz, 3-phase

240 Volt, 50/60 Hz, 3-phase

480 Volt, 50/60 Hz, 3-phase

600 Volt, 60 Hz, 3-phase

International:

380/415 Volt, 50/60 Hz, 3-Ph, (Prevacuum Units)

Sterilizer Feed Water

1.0" NPT, 30 to 50 psig (206.8 to 344.7 kPa) dynamic. Refer to **Table 1** for water specification guidelines.

Steam Generator Feed Water

1/2" NPT, 20 to 50 psig (137.9 to 344.7 kPa) dynamic. Refer to **Table 2** for required water quality. Use of feed water within the nominal conditions will optimize equipment performance and reduce maintenance.

NOTE: Backflow prevention is not standard on the unit, but a backflow preventer option can be ordered.

Sterilizer Equipped With Integral Stainless-steel Steam Generator

Sterilizer Feed Water

1.0" NPT, 30 to 50 psig (206.8 to 344.7 kPa) dynamic. Refer to **Table 1** for required water quality.

Steam Generator Feed Water

1/2" NPT, 20 to 50 psig (137.9 to 344.7 kPa) Refer to **Table 3** for required water quality.

Drain

1-1/2" ODT generator drain terminal. (Floor drain capacity must handle peak water consumption; refer to engineering data.)

Generator Drain

1/2" ODT

Electrical - Controls

120 Volt, 50/60 Hz, 1-phase, 9.5 Amp

International:

230 Volt, 50/60 Hz, 1-Ph, 1.5 Amp

Electrical - Generator

208 Volt, 50/60 Hz, 3-phase

240 Volt, 50/60 Hz, 3-phase

480 Volt, 50/60 Hz, 3-phase

600 Volt, 60 Hz, 3-phase

International:

380/415 Volt, 50/60 Hz, 3-Ph, (Prevacuum Units)

Refer to the Following Equipment Drawings for Installation Details

Equipment Drawing Number	Equipment Drawing Title
AMSCO 110LS	
387362-169	110LS, SINGLE DOOR, RECESSED, STEAM HEAT
387362-170	110LS, SINGLE DOOR, CABINET, STEAM HEAT
387362-171	110LS, SINGLE DOOR, RECESSED, ELECTRIC STEAM
387362-172	110LS, SINGLE DOOR, CABINET, ELECTRIC STEAM
387362-173	110LS, DOUBLE DOOR, RECESSED 1 WALL, STEAM HEAT
AMSCO 250LS	
387362-159	250LS, SINGLE DOOR, RECESSED, STEAM HEAT
387362-160	250LS, SINGLE DOOR, CABINET, STEAM HEAT
387362-161	250LS, SINGLE DOOR, RECESSED, ELECTRIC STEAM
387362-162	250LS SINGLE DOOR, CABINET, ELECTRIC STEAM
387362-163	250LS, DOUBLE DOOR, RECESSED 1 WALL, STEAM HEAT
387362-164	250LS, DOUBLE DOOR, RECESSED 2 WALLS, STEAM HEAT
387362-165	250LS, DOUBLE DOOR, RECESSED 1 WALL, ELECTRIC STEAM
387362-166	250LS, DOUBLE DOOR, RECESSED 2 WALLS, ELECTRIC STEAM

Table 1. Recommended Feed Water Quality for Sterilizers

Condition	Nominal Conditions	Maximum Conditions
Temperature	40°-60°F (4°-16°C)	70°F (21°C)
Total Hardness as CaCO ₃ *	50-120 mg/L	171 mg/L
Total Dissolved Solids	100-200 mg/L	500 mg/L
Total Alkalinity as CaCO ₃	70-120 mg/L	180 mg/L
pH	6.8-7.5	6.5-8.5
Total Silica	0.1 - 1.0 mg/L	2.5 mg/L

* 17.1 mg/L = 1.0 grain hardness

Table 2. Required Feed Water Quality for Carbon-Steel Steam Generators

Condition	Nominal Conditions	Maximum Conditions
Temperature	70-140°F (21-60°C)	140°F (60°C)
Total Hardness as CaCO ₃ *	0-17 mg/L	130 mg/L
Total Dissolved Solids	50-150 mg/L	250 mg/L
Total Alkalinity as CaCO ₃	50-100 mg/L	180 mg/L
pH	6.8-7.5	6.5-8.5
Total Silica	0.1 - 1.0 mg/L	2.5 mg/L
Resistivity †	2 - 6 kΩ·cm	26 kΩ·cm

* 17.1 mg/L = 1.0 grain hardness

† **WARNING-BURN HAZARD:** Never use supply water with resistivity exceeding 26 kΩ·cm, as doing so may cause malfunction of steam generator level control, resulting in sterilizer operator being severely burned by scalding water. If supply water resistivity exceeds 26 kΩ·cm immediately contact STERIS Service Engineering.

Table 3. Required Feed Water Quality Stainless Steel Generators

Type of Water	Deionized Water, Distilled or Reverse Osmosis
Temperature	70-140°F (21-60°C)
Minimum Specific Resistivity	1.0 MΩ·cm

NOTE: Do not connect tap water to stainless-steel steam generator. Use of water not meeting the required feed water quality will invalidate the warranty and is a violation of ASME Boiler Codes.

ENGINEERING DATA

Model & Chamber Size in (mm)	Heating	MAXIMUM OPERATING WEIGHT ^a lbs (kg)		HEAT LOSS ^b BTU/hr at 70°F (21°C)						
				Single Door			Double Door			
		Single Door	Double Door	Cab't Enc	Recessed		Recessed One Wall		Recessed Two Walls	
				To Room	Front of Wall	Back of Wall	Front of Wall	Back of Wall	At Each End	Between Walls
AMSCO 110LS 16 x 16 x 26 (406 x 406 x 660)	Steam	750 (340)	989 (449)	4300	1600	2700	1600	3500	N/A	N/A
	Electric	890 (404)	N/A	6050	2300	3750	N/A	N/A	N/A	N/A
AMSCO 250LS 20 x 20 x 38 (508 x 508 x 965)	Steam	1231 (558)	1606 (728)	7000	2500	4500	2500	5300	2500	2800
	Electric	1371 (622)	1726 (782)	8750	3300	5450	3300	6250	3300	2950

Model & Chamber Size in (mm)	Heating	UTILITIES CONSUMPTION									
		Water ^c							Steam		
		Cold			Hot ^d						
		Peak gpm (lpm)	Per Cycle ^e gal/cycle (l/cycle)	Idle gph (lph)	Peak gpm (lpm)	Per Cycle ^e gal/cycle (l/cycle)	Idle gph (lph)	Peak ^f lb/hr (kg/hr)	Per Cycle ^e lb/cycle (kg/cycle)	Idle lb/hr (kg/h)	
AMSCO 110LS 16 x 16 x 26 (406 x 406 x 660)	Steam	6 (23)	68 (257)	7 (27)	N/A	N/A	N/A	180 (81)	18 (8)	7 (3)	
	Electric	6 (23)	68 (257)	7 (27)	1 (4)	3 (11)	1 (4)	N/A	N/A	N/A	
AMSCO 250LS 20 x 20 x 38 (508 x 508 x 965)	Steam	6 (23)	70 (265)	10 (38)	N/A	N/A	N/A	180 (81)	21 (10)	7 (3)	
	Electric	6 (23)	70 (265)	10 (38)	1 (4)	4 (15)	1 (4)	N/A	N/A	N/A	

^a Based on chamber fully loaded with water flasks.

Noise level is based on the vacuum pump, 74 dB at 24"Hg vacuum.

Estimated noise level of 68dB for units with water ejector.

^b At 70°F (21°C).

^c Backflow preventer device in water line, when required by local codes, is not provided by STERIS.

^d Hot water recommended for units equipped with electric steam heat.

^e Based on Prevac cycle, 3 pulses, 30 minute exposure time and 5 minute dry time. Tested with empty chamber.

^f Peak steam demand (lbs/hr) may vary depending on operating conditions.

Additional utilities are required for units with the following options:

- Liquid Air Cool (Compressed Air)
- Decontamination Cycle (Compressed Air)
- Bio-Seal and Air Differential Seal (Optional Compressed Air Backup)
- Vacuum Pump (3-Phase Voltage)
- Stainless-Steel Piped Units (Treated Water)
- Steam Source (one of the following):
 - >> Integral Steam Generator - Carbon Steel or Stainless Steel (3 Phase Voltage)
 - >> Indirect Steam Generator; Minimum 75 psig Steam Required

Consult Customer service for specially configured equipment drawings.

**CUSTOMER IS RESPONSIBLE FOR COMPLIANCE WITH
APPLICABLE LOCAL AND NATIONAL CODES AND
REGULATIONS.**

**The base language of this document is ENGLISH.
Any translations must be made from the base language
document.**

For further information, contact:



STERIS Corporation
5960 Heisley Road
Mentor, OH 44060-1834 • USA
440-354-2600 • 800-548-4873
www.STERISLifeSciences.com

STERIS Corporation
5960 Heisley Road
Mentor, OH 44060-1834



Friday, June 7, 2024

Attn: Ms. Stephanie Friedman
US EPA
Gulf Breeze, FL
Friedman.Stephanie@epa.gov

Dear Ms. Friedman,

Thank you for your interest in the STERIS AMSCO 250LS Small Scientific Steam Sterilizer. Following is a list of the features and benefits available on the STERIS Sterilizer:

- 1.) Non-clogging chamber drain line prevents media from plugging drain line.
- 2.) 316L stainless steel chamber and jacket.
- 3.) Two-year warranty on steam-activated door gasket.
- 4.) Critical control system components are housed within a sealed compartment to protect from moisture and heat.
- 5.) Allen-Bradley non-proprietary touch-screen PLC control with flash memory card, along with USB, for easier operation.
- 6.) All alarms are printed in full on journal and displayed on the screen. No cross-reference codes are needed.
- 7.) Manual vertical sliding door is a standard feature, no swinging door or manual tightening of radial arm wheels.
- 8.) Waste Bag Cycle is standard for all 250LS Units.
- 9.) Patented optimal solution cooling, controlled by a microprocessor with no presets, is standard.
- 10.) Thermal printer is used with automatic paper storage and cut-out functionality for quick reports that can be attached to loads.
- 12.) Assigned STERIS-employed service representatives in local area who already handles any previous maintenance contracts for on-site unit(s). This translates into a faster and accurate response times.
- 13.) This new equipment can easily be added to any previous or existing Service Contract and may even present you with some savings in said Contract, as newer units carry less liability than older or obsolete ones.
- 14.) These new units would share a pool of locally-sourced and stocked parts for them, most parts are also interchangeable with existing units which again help decrease or eliminate down-time.

To the best of my knowledge, these unique features and benefits are available in combination only on the STERIS 250LS Small Steam Sterilizer. The STERIS 250LS Small Steam Sterilizer is manufactured solely by the STERIS Corporation and is sold through direct STERIS-employed sales representatives.

Please contact me directly at 440-525-6956 if you have any questions.

Sincerely,



Benjamin A. Gomez
Account Manager, Capital Solutions - GA, AL, MS, FL & LA
STERIS Corporation | Life Sciences
Mobile: 440-525-6956
E-Mail: bgomez@steris.com