

# MEPNN Supplier Scouting Opportunity Synopsis

## Section 1: General Information

Scouting Number	2025-053
Item to be Scouted	Spring Clip Washers
Days to be scouted	30
Response Due By	03/28/2025
Description	Spring Clip Washers
Notify Requester Immediately	
State item to be used in	Kansas

## Section 2: Technical Information

Type of supplier being sought	Manufacturer
Reason	BABA
Describe the manufacturing processes (elaborate to provide as much detail as possible)	Includes but is not limited to forging, wire drawing, annealing, coiling, shaping, heat treatment/galvanizing, and surface finishing per ASTM A-153"
Provide dimensions / size / tolerances / performance specifications for the item	See example drawings under additional information
List required materials needed to make the product, including materials of product components	Forged Steel, Hot dip galvanized per ASTM A-153
Are there applicable certification requirements?	Yes
Details	Needs to be Build America, Buy America compliant.
Are there applicable regulations?	No
Are there any other standards, requirements, etc.?	Yes
Details	See example drawings under additional information
NAICS 1	332510 Hardware manufacturing
NAICS 2	111110 Soybean Farming
Additional Technical Comments	

## Section 4: Business Information

Estimated potential business volume	200 in first purchase, 2700 each over 1 year.
Estimated target price / unit cost information (if unavailable explain)	\$8.00 each
When is it needed by?	October 1, 2025
Describe packaging requirements	Box of 50 each. Boxes on pallets. Best available. Delivered undamaged. Specifics discussed in negotiation.
Where will this item be shipped?	Great Bend, Kansas

## Additional Comments

Is there other information you would like to include?

N/A



## WASHER, SPRING CLIP, 7/8in

By Chance  
Catalog # [C2050436](#)



Spring affect of washer is used to counter shrinkage of wood members.

### Features

- Spring clip washer with 15/16" diameter hole for 7/8" diameter bolt
- Material stock size 1/4" thick x 1" wide
- Hot dip galvanized per ASTM A-153
- RUS listed, aw - Washer, spring

### General

Catalog Number	C2050436
Coating	Galvanized, ASTM A-153
Material	Steel
Size	1/4 in x 1-3/4 in
Type	Lockwasher
UPC	096359240617

### Dimensions

Bolt Size	7/8 in
Dimension - Hole Size inch	1 in
Dimensions	3.875 in x 1.750 in x 1.125 in
Distance From Pole	N/A
Height	1.125 in
Length	3.875 in
Weight	0.7 lb
Width	1.75 in

### Logistics

Pallet Quantity	2400
-----------------	------

### Product Assets

- [Catalogs - Communications Catalog](#)
- [Catalogs - Pole Line Hardware](#)
- [Sales Drawings - Spring Clip Washer](#)
- [Specifications - C2050436](#)

CAT. NO.	BOLT SIZE	" A "	" B "	" C "	" D "	" E "	" F "
3539	1/2	1.00	.62	5/32 STK	.62 X .75	2.44	.63
3540	5/8	1.75	.62	1/4 STK	.75 X .88	3.75	.75
3541	3/4	1.75	.62	1/4 STK	.88 X 1.00	3.75	.88
C205-0436	7/8	1.75	.62	1/4 STK	1.00 X 1.13	3.75	1.00
C205-0438	1	1.75	.62	1/4 STK	1.12 X 1.25	3.75	1.12

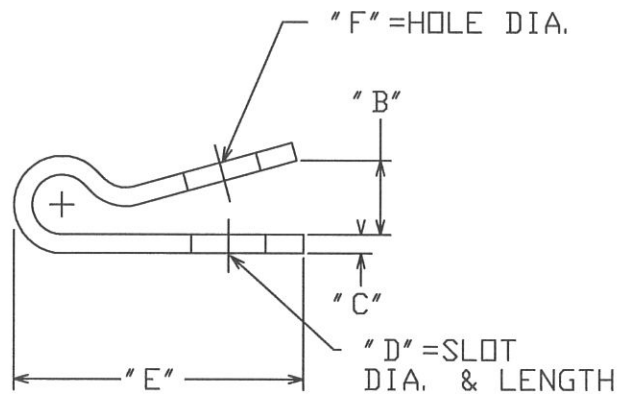
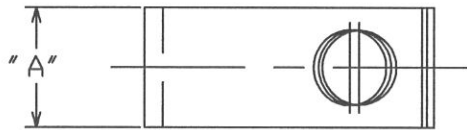

==NOTES==

1. MAT'L: HOT ROLLED STEEL,  
PER ASTM A568
2. FINISH: HOT DIP GALVANIZED,  
PER ASTM. A153 (LATEST REVISION).

CHANCE TOLERANCE CHART		 <b>HUBBELL POWER SYSTEMS</b> <small>POWER SYSTEMS, INC.</small>	
CONFIDENTIAL: THIS DRAWING AND ITS CONTENTS ARE CONFIDENTIAL AND THE EXCLUSIVE PROPERTY OF HUBBELL POWER SYSTEMS. NO PUBLICATION, DISTRIBUTION OR COPIES MAY BE MADE WITHOUT THE WRITTEN CONSENT OF HUBBELL POWER SYSTEMS. HUBBELL POWER SYSTEMS UNPUBLISHED. ALL RIGHTS RESERVED UNDER THE COPYRIGHT LAWS.		<b>TITLE</b> SPRING CLIP WASHER	
SIZE	DWG NO.	CAT / PART / ASSY NO.	REV
SB	SA3539	SEE CHART	D
DO NOT SCALE THIS DRAWING	DRN BY JONES	DATE 01/09/91	SHEET 01 OF 01